



**SCOPING REPORT - SUBMITTED TO THE
DEPARTMENT OF MINERAL RESOURCES AND
ENERGY, NORTHERN CAPE**



**SUBMITTED TO THE
DEPARTMENT OF
MINERAL RESOURCES
AND ENERGY**

JULY 2023



SCOPING REPORT

PROSPECTING RIGHT APPLICATION (WITH BULK SAMPLING) IN TERMS OF SECTIONS 16 AND 20 OF THE MINERAL AND PETROLEUM RESOURCES DEVELOPMENT ACT, 2002 (ACT NO. 28 OF 2002) AS AMENDED BY SECTION 12 OF ACT 49 OF 2008; FOR DIAMONDS, MANGANESE AND IRON ORES AND ASSOCIATED AND / OR RELATED INFRASTRUCTURE, PROCESSES, ACTIVITIES AND EQUIPMENT ON THE FARM GAMOHAAN NO. 438, NEAR KURUMAN, JOHN TAOLO GAETSETWE DISTRICT, NORTHERN CAPE, SOUTH AFRICA.

FOR COMMENT

SUBMITTED FOR ENVIRONMENTAL AUTHORIZATIONS IN TERMS OF THE NATIONAL ENVIRONMENTAL MANAGEMENT ACT, 1998 AND THE NATIONAL ENVIRONMENTAL MANAGEMENT WASTE ACT, 2008 IN RESPECT OF LISTED ACTIVITIES THAT HAVE BEEN TRIGGERED BY APPLICATIONS IN TERMS OF THE MINERAL AND PETROLEUM RESOURCES DEVELOPMENT ACT, 2002 (MPRDA) (AS AMENDED).

NAME OF APPLICANT: DIAMOND MOGULS (PTY) LTD

TEL NO: 067 936 7236

POSTAL ADDRESS: 09 SESING STREET, GALESHEWE, KIMBERLEY, NORTHERN CAPE, 8345

PHYSICAL ADDRESS: 09 SESING STREET, GALESHEWE, KIMBERLEY, NORTHERN CAPE, 8345

AUTHORS: Kwindla Nobaza (EAP)

FILE REFERENCE NUMBER SAMRAD: NC 30/5/1/1/2/13433 PR

I. IMPORTANT NOTICE

In terms of the Mineral and Petroleum Resources Development Act (Act 28 of 2002 as amended), the Minister must grant a prospecting or mining right if among others the mining “will not result in unacceptable pollution, ecological degradation or damage to the environment”.

Unless an Environmental Authorisation can be granted following the evaluation of an Environmental Impact Assessment and an Environmental Management Programme report in terms of the National Environmental Management Act (Act 107 of 1998) (NEMA), it cannot be concluded that the said activities will not result in unacceptable pollution, ecological degradation or damage to the environment.

In terms of section 16(3)(b) of the EIA Regulations, 2014, any report submitted as part of an application must be prepared in a format that may be determined by the Competent Authority and in terms of section 17 (1) (c) the competent Authority must check whether the application has taken into account any minimum requirements applicable or instructions or guidance provided by the competent authority to the submission of applications.

It is therefore an instruction that the prescribed reports required in respect of applications for an environmental authorisation for listed activities triggered by an application for a right or a permit are submitted in the exact format of, and provide all the information required in terms of, this template. Furthermore, please be advised that failure to submit the information required in the format provided in this template will be regarded as a failure to meet the requirements of the Regulation and will lead to the Environmental Authorisation being refused.

It is furthermore an instruction that the Environmental Assessment Practitioner must process and interpret his/her research and analysis and use the findings thereof to compile the information required herein. (Unprocessed supporting information may be attached as appendices). The EAP must ensure that the information required is placed correctly in the relevant sections of the Report, in the order, and under the provided headings as set out below, and ensure that the report is not cluttered with un-interpreted information and that it unambiguously represents the interpretation of the applicant.

II. Acronyms

AEL	Atmospheric Emission License
AQMP	Air Quality Management Plan
BAR	Basic Assessment Report
B-BBEE	Broad-Based Black Economic Empowerment
BPG	Best Practice Guideline
CA	Competent Authority
CMA	Catchment Management Agency
CMS	Catchment Management Strategy
COMSA	Chamber of Mines South Africa
CPA	Communal Property Association
CRR	Comments and Responses Report
DEFF	Department of Environment, Forestry and Fisheries
DENC	Department of Environment and Nature Conservation
DARDLR	Department of Agriculture, Rural Development and Land Reform
DMRE	Department of Mineral Resources and Energy
DMR	Department of Mineral Resources
DSR	Draft Scoping Report
DWA	Department of Water Affairs
DWS	Department of Water and Sanitation
DWAF	Department of Water Affairs and Forestry
EA	Environmental Authorisation
EAP	Environmental Assessment Practitioner
EC	Electrical Conductivity
ECO	Environmental Control Officer
EI	Ecological Importance
EIA	Environmental Impact Assessment
EIS	Ecological Importance and Sensitivity
EMP	Environmental Management Plan
EMPr	Environmental Management Programme
EMS	Environmental Management System
ES	Ecological Sensitivity
ESMS	Environmental and Social Management System
FIER	Final Environmental Impact Report
FEPA	Freshwater Ecosystem Priority Areas
FSR	Final Scoping Report
GDP	Gross Domestic Product
GN	Government Notice

Ha	Hectares
HDPE	High Density Polyethylene
I&AP's	Interested and Affected Parties
IDP	Integrated Development Plan
IEMPr	Integrated Environmental Management Programme
ISO	International Organisation for Standardisation
IWRM	Integrated Water Resources Management
IWULA	Integrated Water Use License Application
IWWMP	Integrated Water and Waste Management Plan
MAE	Mean Annual Evaporation
MAP	Mean Annual Precipitation
MAR	Mean Annual Runoff
MPRDA	Mineral and Petroleum Resources Development, 2002 (Act No. 28 of 2002)
MR	Mining Right
MSDS	Material Safety Data Sheet
NEMA	National Environmental Management Act, 1998 (Act No. 107 of 1998)
NEM:AQA	National Environmental Management: Air Quality Act, 2004 (Act No. 39 of 2004)
NEM:WA	National Environmental Management: Waste Act, 2008 (Act No. 59 of 2008)
NFEPA	National Freshwater Ecosystem Priority Areas
NCDAEARDLR	Northern Cape: Department of Agriculture, Environmental Affairs, Rural Development and Land Reform
NHRA	National Heritage Resources Act, 1999 (Act No. 25 of 1999)
NWA	National Water Act, 1998 (Act No. 36 of 1998) [as amended]
NWRS	National Water Resource Strategy
PCO	Pest Control Officer
PES	Present Ecological Status
PM ₁₀	Particulate matter with an aerodynamic diameter of less than 10 µm
PM _{2.5}	Particulate matter with an aerodynamic diameter of less than 2.5 µm
PPP	Public Participation Process
RWD	Return water dam
SABS	South African Bureau of Standards
SACNASP	South African Council for National Scientific Professions
SAHRA	South African Heritage Resources Agency
SANAS	South African National Accreditation System
SANBI	South African National Biodiversity Institute
SANS	South African National Standard
SAWQG	South African Water Quality Guidelines
SDF	Spatial Development Framework
S&EIR	Scoping and Environmental Impact Report

SHE	Safety, Health and Environment
SHEQ	Safety, Health, Environment and Quality
SIA	Social Impact Assessment
SR	Scoping Report
TDS	Total Dissolved Salts
TOPS	Threatened or Protected Areas
ToR	Terms of Reference
TSS	Total Suspended Solids
VOC	Volatile Organic Compound
WARMS	Water Authorisation Registration and Management System
WCDM	Water Conservation and Demand Management
WESSA	Wildlife and Environmental Society of South Africa
WMA	Water Management Area
WMP	Waste Management Plan
WRC	Water Research Commission
WUL	Water Use License

II. SOME DEFINITIONS

Catchment - The area from which any rainfall will drain into the watercourse or watercourses or part of the water course, through surface flow to a common point or common points

Constitution – Refers to the Constitution of the Republic of South Africa, 1996 (Act No. 108 of 1996).

Domestic waste - Waste, excluding hazardous waste that emanates from premises that are used wholly or mainly for residential, educational, health care, sport or recreation purposes;

Effective Management of Waste or Spills - Means the taking of all practicable steps to ensure that waste is managed in a manner that will protect health, property and the environment;

Environment – The external circumstances, conditions and objects that affect the existence and development of an individual, organism or group; these circumstances include biophysical, social, economic, historical, cultural and political aspects. Environment means the surroundings within which humans exist and that are made up of-

(i) the land, water and atmosphere of the earth;

(ii) micro-organisms, plant and animal life;

(iii) any part or combination of (i) and (ii) and the interrelationships among and between them; and

(iv) the physical, chemical, aesthetic and cultural properties and conditions of the foregoing that influence human health and well-being.

Environmental Impact Assessment - An environmental Impact Assessment (EIA) refers to the process of identifying, predicting and assessing the potential positive and negative social, economic and biophysical impacts of any proposed project, plan, programme or policy which requires authorisation of permission by law and which may significantly affect the environment. The EIA includes an evaluation of alternatives. As well as recommendations for appropriate mitigation measures for minimising or avoiding negative impacts, measures enhancing the positive aspects of the proposal and environmental management and monitoring measures.

Existing Lawful use - An existing lawful use means a water use which has taken place at any time during a period of two years immediately before the date of commencement of the National Water Act 1998, (Act 36 of 1998) or which has been declared an existing lawful water use under section 33 and which was authorised by or under any law which was in force immediately before the date of commencement of the National Water Act.

Groundwater Recharge - The inflow of water into a groundwater reservoir from the surface, e.g. infiltration of precipitation and its movement to the water table.

General waste - Means waste that does not pose an immediate hazard or threat to health or to the environment, and includes-

(a) domestic waste;

(b) building and demolition waste;

(c) business waste; and

(d) inert waste.

Hazardous waste - Means any waste that contains organic or inorganic elements or compounds that may, owing to the inherent physical, chemical or toxicological characteristics of that waste, have a detrimental impact on health and the environment

Hydrogeological –The study of distribution and movement of groundwater.

Hydrological – The study of movement, distribution and quality of surface water and groundwater.

Inert waste - Means waste that-

- (a) does not undergo any significant physical, chemical or biological transformation after disposal;
- (b) does not burn, react physically or chemically biodegrade or otherwise adversely affect any other matter or environment with which it may come into contact; and
- (c) does not impact negatively on the environment, because of its pollutant content and because the toxicity of its leachate is insignificant;

Monitoring programme - means a programme for taking regular measurements of the quantity and/or quality of a water resource, waste or wastewater discharge at specified intervals and at specific locations to determine the chemical, physical and biological nature of the water resource, waste or wastewater discharge.

Public Participation Process – A process of involving the public in order to identify issues and concerns, and obtain feedback on options and impacts associated with a proposed project, programme or development. Public Participation Process in terms of NEMA refers to: a process in which potential interested and affected parties are given an opportunity to comment on, or raise issues relevant to specific matters.

Red Data Book (South African) – An inventory of rare, endangered, threatened or vulnerable species of South African plants and animals.

Recycle - Means a process where waste is reclaimed for further use, which process involves the separation of waste from a waste stream for further use and the processing of that separated material as a product or raw material.

Reserve - means the quantity and quality of water required –

- (a) to satisfy basic human needs by securing a basic water supply, as prescribed under the Water Services Act, 1997 (Act No. 108 of 1997), for people who are now or who will, in the reasonably near future, be -
 - (i) relying upon;
 - (ii) taking water from; or
 - (iii) being supplied from, the relevant water resource; and
- (b) to protect aquatic ecosystems in order to secure ecologically sustainable development and use of the relevant water resource.

Re-use - Means to utilise articles from the waste stream again for a similar or different purpose without changing the form or properties of the articles;

The Act - The National Water Act, (NWA) (Act 36 of 1998)

Tributaries - A stream or river which flows directly into a larger river or stream.

Waste - Means any substance, whether or not that substance can be reduced, re-used, recycled and recovered-

(a) that is surplus, unwanted, rejected, discarded, abandoned or disposed of;

(b) which the generator has no further use of for the purposes of production;

(c) that must be treated or disposed of; or

(d) that is identified as a waste by the Minister by notice in the Gazette, and includes waste generated by the mining, medical or other sector,

but –

(i) a by-product is not considered waste; and

(ii) Any portion of waste, once re-used, recycled and recovered, ceases to be waste.

Hazardous waste must be classified in terms of SANS 10228 class.

Class 1: Explosives

Class 2: Gases

Class 3: Flammable liquids

Class 4: Flammable solids

Class 5: Oxidising substances and organic peroxides

Class 6: Toxic and infectious substances

Class 7: Radioactive substances

Class 8: Corrosives

Class 9: Other miscellaneous substances

If not listed in SANS 10228 - consult DWS prior to classification.

Watercourse means -

(a) a river or spring;

(b) a natural channel in which water flows regularly or intermittently;

(c) a wetland, lake or dam into which, or from which, water flows; and

(d) any collection of water which the Minister may, by notice in the Gazette, declare to be a watercourse, and a reference to a watercourse includes, where relevant, its bed and banks.

Water quality means the physical, chemical, toxicological, biological (including microbiological) and aesthetic properties of water that determine sustained (1) healthy functioning of aquatic ecosystems and (2) fitness for use (e.g. domestic, recreational, agricultural, and industrial). Water quality is therefore reflected in (a) concentrations or loads of substances (either dissolved or suspended) or micro-organisms, (b) physico-chemical attributes (e.g. temperature) and (c) certain biological responses to those concentrations, loads or physico-chemical attributes.

Water Resource - A water resource includes any watercourse, surface water, estuary or aquifer. Watercourses include rivers, springs, and natural perennial and non-perennial channels. Wetlands, lakes, dams, or any collection identified as such by the Minister in the Government Gazette.

Water use license - An authorisation from the Department to a designated water user to use water. The authorisation will provide details on the time-frames and conditions for the designated water use

Contents

I.	IMPORTANT NOTICE	iii
II.	Acronyms	iv
II.	SOME DEFINITIONS	vii
III.	Objective of the scoping process	xv
IV.	PART A.....	3
1.	Introduction	3
1.1	Background	3
2.	Need and Desirability	5
2.1	Prospecting for Mineral Resources Development	5
2.2	National Development Plan 2030	6
3.	Project Overview	7
3.1	Approach to the EIA Studies	9
3.1.1	Scoping Report Phase (SRP)	14
3.1.2	Environmental Impact Assessment Phase / Study	15
3.2	Details of Consultant and Environmental Impact Assessment Practitioner	17
3.3	Structure of this Scoping Report	18
3.4	The location of the activity, including-	20
3.4.1	The 21-digit Surveyor General code of each cadastral and land parcel	20
3.4.2	where available, the physical address and farm name	20
3.4.3	where the required information on 3.4.1 and 3.4.3 is not available, the coordinates of the boundary of the properties	20
4	a plan which locates the proposed activity or activities applied for at an appropriate scale, or, if it is –	20
4.1	A linear activity, a description and coordinates of the corridor in which the proposed activity or activities is to be undertaken; or	22
4.2	On land where the property has not been defined, the coordinates within which the activity is to be undertaken	22
	Description of Planned Non-Invasive Activities	24
	Description of Planned Invasive Activities	24
7.14.1	Provincial Legislation	57
8	Public Participation Process	58
8.1	Overview of the Public Participation Process Undertaken during the Scoping Phase	59
8.2	Availing of Background Information	60
8.3	Identification of Key Stakeholders	60
8.4	Advertising	61
8.5	Site Notices	61

8.6	Review of Environmental Scoping Report	62
8.6.1	Sharing of Draft Scoping Report with Interested and Affected Parties who requested for a copy	62
8.6.2	Authority Review of Draft Environmental Scoping Report	62
8.6.3	Public Review of Draft Environmental Scoping Report	62
8.6.4	Final Environmental Scoping Report	63
9	General or Baseline Description of the Study Area	63
9.1.1	Locality	63
9.1.3	Climate	70
9.1.4	Agricultural Potential.....	70
9.1.5	Surface Water.....	71
9.1.6	Groundwater.....	71
9.1.7	Topography	71
9.1.8	Biodiversity.....	71
9.1.9	Wetlands	72
9.1.10	Waste	72
9.1.11	Heritage and Cultural Resources	73
9.1.12	Socio-economic	73
9.1.13	Land Uses	73
9.1.14	Visual Amenity.....	74
9.1.15	Noise and Vibration	74
9.1.16	Traffic	74
9.1.17	Air Quality	75
9.1.18	Site Sensitivity	75
9.2	Site Selection Matrix.....	75
9.3	Concluding Statement on Alternatives	76
9.	Potential Environmental Impacts.....	76
9.1	Construction Phase	76
9.2	Operational Phase	77
9.3	A Description of the Environmental Impacts and Risks Identified During the Environmental Assessment Process	78
10.	Conclusion and Recommendations.....	81
11.	Plan of Study for EIA.....	81
11.1	Introduction	81
11.2	Process Phases	82
11.2.1	Scoping Phase.....	82
11.2.2	Environmental Impact Assessment	82

11.3	Conduct Impact Assessment	82
11.3.1	Rating of Impact	82
11.4	Anticipated Outcomes of the Impact Assessment Phase	89
11.5	Proposed Specialist Studies	90
11.5.1	Heritage Impact Assessment (Field Survey), inclusive of Palaentological Impact Assessment (Desktop Study) 90	
11.5.2	Biodiversity Assessment Study	90
11.5.3	Air Quality Impact Assessment	91
11.5.4	Wetland Assessment	92
11.5.5	Social Impact Assessment	93
11.6	Compile the Environmental Impact Assessment Report	94
11.7	Review of Environmental Impact Assessment Report	94
11.7.1	Public Review of the Draft Environmental Impact Assessment Report	94
11.7.2	Authority Review of the Draft Environmental Impact Assessment Report	95
12.	An undertaking or affirmation by the EAP in relation to [:-]	96

List of Figures

Figure 1: Annual incoming short-wave radiation for South Africa (SolarGIS)	8
Figure 2: Project Application Area	21
Figure 3: Locality Map of John Taolo Gaetsewe District	22
Figure 4: Schematic representation of the planned process flow	33
Figure 5: Schematic representation of the planned process flow for diamond processing.	34
Figure 6: Section of a typical Jaw Crusher	37
Figure 7: Schematic diagram of Gyratory Crusher	38
Figure 8: Schematic diagram of Cone Crusher	39
Figure 9: Dense Medium Separation	40
Figure 10: Schematic representation of Jig Plant.....	41
Figure 9: Schematic diagram of typical flow of sintering plant	43
Figure 12: Typical flow diagram of KOBELCO pelletizing system.	43
Figure 13: Project Application Area	64
Figure 14: Locality Map of ZF Mgawu District.....	65
Figure 15: A simplified geological area of Kuruman (Moen, 1979)	68

List of Tables

Table 1: Listed and Specified Activities.....	10
Table 2: Details of the Consultant and EAP	17
Table 3: Structure of Scoping Report	18
Table 4: Property Information	20
Table 5: GPS Co-ordinates	Error! Bookmark not defined.
Table 6: Bulk Sampling Activities	36
Table 7: Classes of Ores.....	42
Table 8: Lithostratigraphic column of the Kuruman Area	69
Table 9: Environmental Impacts and Risks Identified	78
Table 10: Criteria for determination of ratings	85
Table 11: Determination of Environmental Risk	87
Table 12: Determination of Prioritisation Factor	88
Table 13: Significance Rating	88

III. Objective of the scoping process

The objective of the scoping process is to, through a consultative process—

- (a) Identify the relevant policies and legislation to the activity;
- (b) Motivate the need and desirability of the proposed activity, including the need and desirability of the activity in the context of the preferred location;
- (c) Identify and confirm the preferred activity and technology alternative through an identification of impacts and risks and ranking process of such impacts and risks;
- (d) Identify and confirm the preferred site, through a detailed site selection process, which includes an impact and risk assessment process inclusive of cumulative impacts and ranking process of all the identified alternatives focusing on the geographical, physical, biological, social, economic, and cultural aspects of the environment;
- (e) Identify the key issues to be addressed in the assessment phase;
- (f) Agree on the level of assessment to be undertaken, including the methodology to be applied, the expertise required as well as the extent of further consultation to be undertaken to determine the impacts and risks the activity will impose on the preferred site through the life of the activity, including the nature, significance, extent, duration and probability of the impacts to inform the location of the development footprint within the preferred site; and
- (g) Identify, through a ranking of the site sensitivities and possible impacts, the activity and technology alternatives will impose on the sites and location identified through the life of the activity to—
 - (i) identify and motivate a preferred site, activity and technology alternative;
 - (ii) identify suitable measures to manage, avoid or mitigate identified impacts; and
 - (iii) identify residual risks that need to be managed and monitored.

IV. PART A

SCOPE OF ASSESSMENT AND ENVIRONMENTAL IMPACT ASSESSMENT REPORT

1. Introduction

South Africa is a developing country within a global space where environmental impacts may not be ignored any longer. The need for sustainable development in a State such as South Africa is accompanied by numerous obligations. Some of these obligations include developing the economy and protecting the environment. In an attempt to protect the environment through impact management in many ways, the international community has entered into agreements and treaties in order to address matters relating to impacts associated with development among others. As a consequence, South Africa is a signatory to a number of international treaties. Some of these treaties include the Paris Agreement on Climate Change. In order to meet the objectives of the Paris Agreement, South Africa is currently promoting renewable energy generation and innovative mining practices among other things.

The economy of South Africa relies largely on both mining and agriculture. The Northern Cape Province in particular relies on both mining and agriculture among other things. However, the province is relatively dry with high evaporation rate. This factor reduces availability of surface water resources in the Northern Cape Province.

Environmental Impact Assessment (EIA) plays a vital role in informing prospecting right applicants of sustainable methods of practising mining at all stages of the process. If properly implemented, Environmental Impact Assessments assist in ensuring optimal use of available resources, productivity increase and sustainability.

1.1 Background

Diamond Moguls (Pty) Ltd proposes to prospect for Diamonds, Iron and Manganese Ores and associated / related infrastructure, activities, process and equipment on the Farm Gamohaam No. 438, near Kuruman, John Taolo Gaetsewe District, Northern Cape, South Africa.

In relation to the mineral resources proposed development and Environmental Impact Assessment must be undertaken. The planned study is going to consider all necessary factors in order to investigate potential impacts of the proposed development against the triple bottom-line of social, economic and environmental impacts.

The concept of sustainable development provides a framework for reconciling socio-economic development and environmental protection. The constitutional framework: Sustainable development is recognised in the Bill of Rights (section 24(b) of the Constitution). In terms of this section, the government must give effect to this right through reasonable legislative and other measures. The Constitution also provides for cooperative governance, which facilitates the implementation of sustainable development.

Sustainable development forms the basis of environmental policy. The White Paper on Environmental Policy states that sustainable development is an overarching goal. The National Environmental Management Act, 1998 (Act No. 107 of 1998) (NEMA), as amended is the framework legislation for the environment and it contains uniform norms and standards applicable to all environmental legislation. One of these norms is sustainable development. The NEMA defines sustainable development as “the integration of social, economic and environmental factors into planning, implementation and decision-making to ensure that development serves present and future generations”. Sustainable development underpins many principles and objectives of environmental management set out in the NEMA. The NEMA also provides the framework for compliance with and the enforcement of environmental legislation. Sustainable development is included in sectorial legislation relating to the environment (i.e. the National Water Act, 1998 (Act No. 36 of 1998), the Mineral and Petroleum Resources Development Act, 2002 (Act No. 28 of 2002), the National Environmental Management: Biodiversity Act, 2004 (Act No. 10 of 2004) and the Local Government: Municipal Systems Act, 2000 (Act No. 32 of 2000)).

The proposed development, intrinsically, requires the implementation of procedures and mechanisms to facilitate co-operative environmental governance. Chapter 3 of the NEMA deals with such procedures. Section 11 of the NEMA makes provision for environmental implementation plans and management plans. Every national department listed in Schedule 2 must prepare an environmental management plan. The provinces and departments must further ensure that these environmental implementation or management plans are consistent. The purpose and objectives of these plans are to:

- coordinate and harmonise the environmental policies, plans, programmes and decisions of the various listed national departments and of provincial and local spheres of government, which must be done to minimise the duplication of procedures and functions and to promote consistency;
- give effect to the principle of cooperative government in Chapter 3 of the Constitution;
- secure the protection of the environment across the country as a whole;

- prevent unreasonable actions by provinces in respect of the environment, which actions are prejudicial to the economic or health interests of other provinces or the country as a whole; and
- enable the Minister to monitor the achievement, promotion and protection of a sustainable environment.

2. Need and Desirability

2.1 Prospecting for Mineral Resources Development

Sustainability in prospecting for mineral resources development is one of the key factors to consider as it plays a pivotal role in ensuring effective and efficient implementation of industry's best practices. The developing countries such as South Africa need now, more than ever, to ensure continued support, maintenance and monitoring of prospecting for mineral resources development as the world faces climate change which threatens the balance in the ecosystem among other things. The mining sector is one of the most important sectors of the South African economy. Not only does it contribute towards the country's GDP, the sector also contributes in poverty elevation, job creation and efficient spatial and land use in some ways. These factors or aspects of the mining sector have to be considered in policy formulation in order to ensure sustainability for current and future generations.

Land uses in South Africa are regulated. The process of spatial and land use change through zoning are easy to understand and implement. They are influenced by many factors such as population growth, household formation and economic development.

In order to meet current and future demands, technology that is applicable in mining-related projects has been evolving. Mining technologies may be used by both emerging miners and established mining houses for more effective and sustainable use of limited water resources. It is pertinent to know the correct quantities of water and frequency to use in mining-related projects. The Responsible Authority for use of water resources in South Africa is currently the Department of Human Settlements, Water and Sanitation. Accordingly, an Integrated Water Use License is going to be lodged with the Responsible Authority in respect of the proposed development.

The primary beneficiaries of this project include, among others, the employees, members of surrounding communities and the country. Secondary beneficiaries include the suppliers of goods and services, and the local businesses through the buying power of employees. This is in line with the National Development Plan (NDP). The Social Labour Plan of the proposed development is aimed at ensuring local economic development through implementation of the various projects.

The applicant estimates that these small pieces of land could, if prospecting rights are granted, prove to be bearing commodities of high economic value. Only small portions of the farms that are targeted will be temporarily disturbed. The remainder of the farm portions will proceed as normal.

2.2 National Development Plan 2030

The National Development Plan envisions a South Africa where “everyone feels free yet bounded to others”; where everyone embraces their full potential, a country where “opportunity is determined not by birth, but by ability, education and hard work”. A South Africa where “we participate fully in efforts to liberate ourselves from the conditions that hinder the flowering of our talents” as articulated in the Vision 2030.

- The NDP aims to achieve the following objectives by year 2030: Uniting South Africans of all races and classes around a common programme to eliminate poverty and reduce inequality;
- Encourage citizens to be active in their own development, in strengthening democracy and in holding their government accountable;
- Raising economic growth, promoting exports and making the economy more labour absorbing;
- Focusing on key capabilities of both people and the country;
- Capabilities include skills, infrastructure, social security, strong institutions and partnerships both within the country and with key international partners;
- Building a capable and developmental state; and
- Strong leadership throughout society that work together to solve our problems

At the core of the Nation Development Plan is the aim to ensure the achievement of a “decent standard of living” for all South Africans by 2030. A “decent standard of living” entails the following core elements as enshrined in the Bill of Rights:

- Housing, water, electricity and sanitation;
- Safe and reliable public transport;
- Quality education and skills development;
- Safety and security;
- Quality health care;
- Social protection;
- Employment;
- Recreation and leisure;
- Clean environment; and

- Adequate nutrition

South Africa's National Development Plan (NDP) 2030 was adopted by Government in year 2012.

3. Project Overview

The Northern Cape Province is, by enlarge, a semi-arid part of South Africa. The limited Surface Water resources in the province impact negatively on the possibility of developing projects that require use of substantial water quantities such as mining and agriculture. However, an alternative solution to the challenge exists. Water for mining-related projects could be sourced from groundwater resources. Diamond Moguls (Pty) Ltd lodged applications with the Department of Mineral Resources and Energy for prospecting right in terms of the Mineral and Petroleum Resources Development Act, 2002 (Act No. 28 of 2002) and an integrated environmental authorisation in terms of both the National Environmental Management Act, 1998 (Act No. 107 of 1998) and the National Environmental Management: Waste Act, 2008 (Act No. 59 of 2008). In response to the acceptance of the MPRDA application, the first phase of the Environmental Impact Assessment (EIA) process is underway. As part of the first phase of the EIA process to investigate the impact that the proposed development is going to have on the environment, this piece of work (Scoping Report) is prepared and subjected to a public participation process. In order to support the proposed development and associated activities, and processes, an Integrated Water Use License Application has to be lodged with the Department of Human Settlements, Water Sanitation (DHSWS) in terms of the National Water Act, 1998 (Act No. 36 of 1998). It is envisaged that the project team is going to abstract water from underground on site. In an event, a different arrangement other than the one envisaged is made, both the Responsible Authority (DHSWS) and the Competent Authority (DMRE) will be consulted.

The increase in population growth that was experienced globally in the past century continued to create challenges as well as opportunities for various sectors of our economy, including the mining sector. The unemployment rate in South Africa is reaching alarming levels. The Northern Cape Province is no exception to having high unemployment rate. A need does exist for projects that create jobs to be developed.

South Africa is exposed to some of the highest intensities of solar radiation in the World. The average daily solar radiation in South Africa varies between 4.5 and 6.5 kWh/m² (16 and 23 MJ/m²). The Northern Cape Province experiences even more intense solar radiation than the other parts of South Africa (Figure 1) which is indicative of high solar resource potential for solar photovoltaic and solar thermal power

generation, which are just some of many desired projects that mining houses could invest on as a part of Social and Labour Plan.

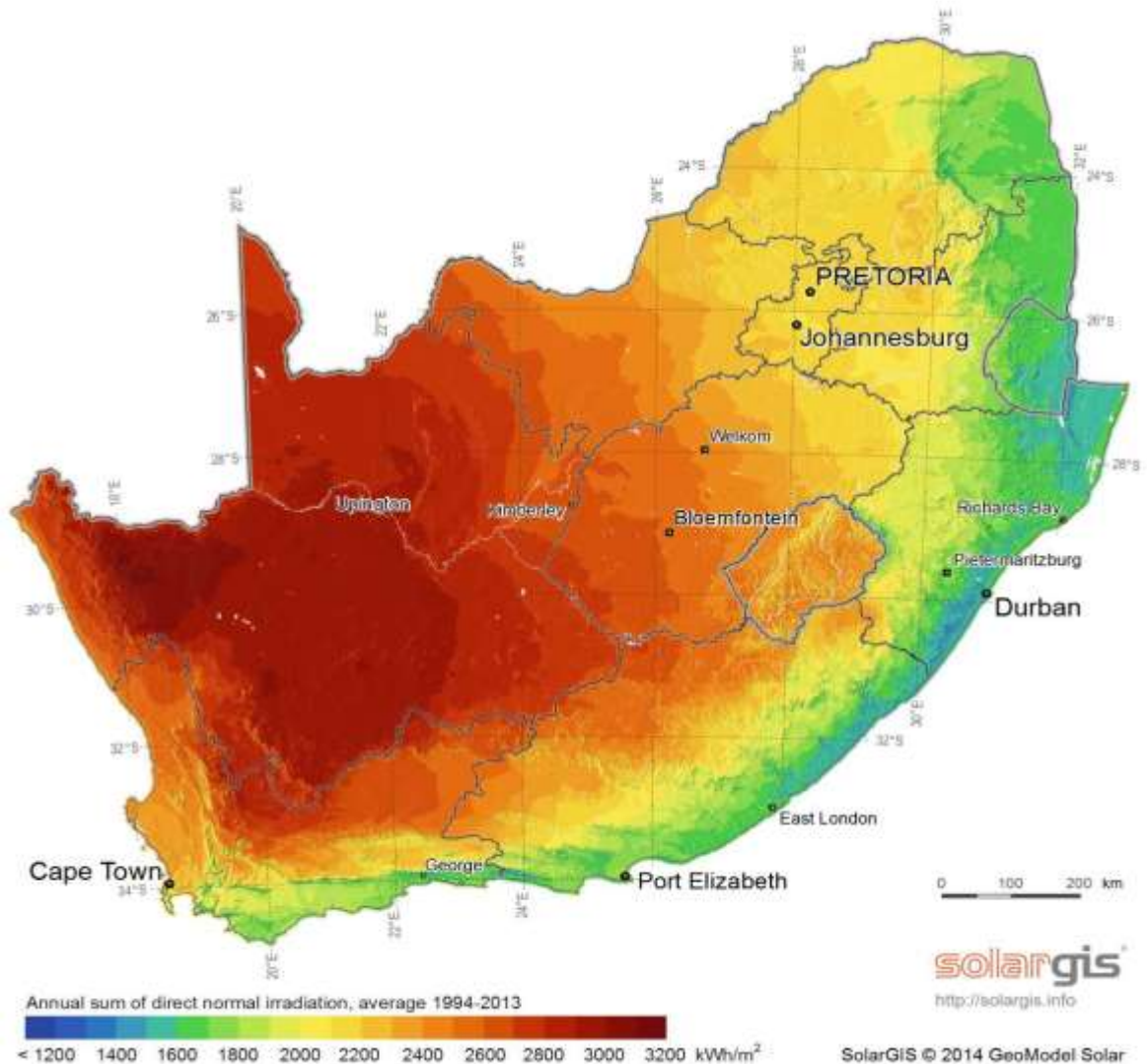

Figure 1: Annual incoming short-wave radiation for South Africa (SolarGIS)

This piece of work focuses on the planning, construction, operation, decommissioning and closure of the proposed prospecting for mineral resources development and related and / or associated Infrastructure, activities, processes and equipment on the Farm Gamohaan No. 438, near Kuruman, John Taolo Gaetsewe District, Northern Cape, South Africa.

3.1 Approach to the EIA Studies

Section 24(1) of the National Environmental Management Act, 1998 (Act No. 107 of 1998) states:

- *"In order to give effect to the general objectives of integrated environmental management laid down in this Chapter, the potential impact on the environment of listed activities must be considered investigated, assessed and reported to the competent authority charged by this Act with granting the relevant environmental authorization."*

Reference is made to "listed activities" in Section 24 of the NEMA. Listed activities relate to the regulations as promulgated in GN R327, R326, R325 and R324 in Government Gazette 40772, dated 7 April 2017. Currently, the Government Notice Regulations published by the Minister in terms of the NEMA relate to the NEMA EIA Regulations in order to specify listed activities that require either a Basic Assessment process, or Scoping and Environmental Impact Assessment (that is a "full EIA"). It is important to note that the proposed development requires a full EIA, as it particularly includes, *inter alia*, the inclusion of Listed Activity Number 15 in GN R325:

- *"The clearance of an area of 20 hectares or more of indigenous vegetation, excluding where such clearance of indigenous vegetation is required for—
(i) the undertaking of a linear activity; or
(ii) maintenance purposes undertaken in accordance with a maintenance management plan."*

All the listed and specified activities which are triggered by this proposed development are going to be submitted to the Competent Authority before the Integrated Environmental Authorisation process underway completes. A copy of this Scoping Report is also going to be submitted to the Department of Mineral Resources and Energy for review. The Reference Number relating to the proposed agricultural development was pending at the time of submitting the first draft. A copy of the Application Form that was to be submitted to the Competent Authority at application stage, together with the anticipated acknowledgement letter (if applicable) from the Competent Authority will be included as an appendix to the Final Scoping Report that will be submitted to the Department of Mineral Resources and Energy for decision-making (in accordance with Regulation 21 (1) of the 2017 EIA Regulations).

The listed and specified activities potentially triggered by the proposed prospecting for mineral resources development are indicated in Table 1.

Table 1: Listed and Specified Activities

NAME OF ACTIVITY E.g. for mining,- excavations, blasting, stockpiles, discard dumps or dams, Loading, hauling and transport, Water supply dams and boreholes, accommodation, offices, ablution, stores, workshops, processing plant, storm water control, berms, roads, pipelines, power lines, conveyors, etc...etc...etc.)	Aerial extent of the Activity Ha or m ²	LISTED ACTIVITY Mark with an X where applicable or affected.	APPLICABLE LISTING NOTICE (GNR 324, GNR 325 or GNR 326)
The extraction, removal and disposal of minerals that is envisaged in terms of Section 20 of the Minerals and Petroleum Resources Development Act, 2002 (Act 28 of 2002) ("Act"), including affected infrastructure, structures and earthworks, directly related to prospecting of a mineral resource and activities for which an exemption has been issued in terms of Section 106 of the Act. Activity 19 of Listing Notice 2	900 Ha	X	GNR 325 Listing Activity 19
All activities, including the operation of a particular activity associated with primary processing of a mineral resource such as extraction, classifying, reduction, concentrating, winning, crushing, screening and washing but excluding the smelting, beneficiation, refining, calcining or gasification of the mineral resource in which case Activity 6 of this Notice applies. Activity 21 of Listing Notice 2	0.96 Ha	X	GNR 325 Listing Activity 21
Clearance of indigenous vegetation	900 Ha - Only the area where prospecting activities are going to take place will be cleared of indigenous vegetation. Concurrent rehabilitation will be conducted with normal backfilling.	X	GNR. 325, Listing Activity 15

Temporary structures (3 x Park Homes)	0.215 ha		GNR 325, Listed 1, Activity 21
Temporary Dump Site	0.19 ha		GNR 325, Listed 1, Activity 21
Residue Dam	0.5 ha		GNR 325, Listed 1, Activity 21
Concrete spillage control at diesel bousers	100 m ²		Not listed
Oil storage facility	100 m ²		GNR 325, Listed 1, Activity 21
Water pipeline of undetermined length but less than 10 Km	3 Km		GNR 325, Listed 1, Activity 21
Roads to trenches and processing plant	+ - 1 Km		GNR 325, Listed 1, Activity 21
Stockpiling of topsoil	900 ha – 3m X 2m X 1 000m pit (200 pits) 200m X 100m X 200m trench (20 trenches)		GNR 325, Listed 1, Activity 21
Handling of General Waste (The waste licensing process for listed activities under Schedule 1 in the National Environment Management Waste Act 2008 is as defined in the environmental impact assessment (EIA) regulations made under section 24(5) of the National Environment Management Act 2008 (NEMA) No. 107 of 1998. This is a Category A Waste License Application for listed activities under Schedule 1 in the National Environment Management Waste Act 2008.)	0.0008 ha	X	NEM:WA - Government Notice Regulation 921 – 29 November 2013
The development of infrastructure exceeding 1 000 metres in length for the bulk transportation of water or storm water— (i) with an internal diameter of 0,36 metres or more; or (ii) with a peak throughput of 120 litres per second or more;	Approx. 2 Km	X	Listing Notice GNR 327, Activity 9

<p>The development and related operation of infrastructure exceeding 1 000 metres in length for the bulk transportation of sewage, effluent, process water, waste water, return water, industrial discharge or slimes –</p> <p>(i) with an internal diameter of 0,36 metres or more; or</p> <p>(ii) with a peak throughput of 120 litres per second or more;</p>	<p>Approx. 2 Km</p>	<p>X</p>	<p>Listing Notice GNR 327, Activity 10</p>
<p>Any activity including the operation of that activity which requires a prospecting right in terms of section 16 of the Mineral and Petroleum Resources Development Act, 2002 (Act No. 28 of 2002), including—</p> <p>(a) associated infrastructure, structures and earthworks, directly related to prospecting of a mineral resource[,] ; or [including activities for which an exemption has been issued in terms of section 106 of the Mineral and Petroleum Resources Development Act, 2002 (Act No. 28 of 2002)]</p> <p>(b) the primary processing of a mineral resource including winning, extraction, classifying, concentrating, crushing, screening or washing; but excluding the secondary processing of a mineral resource, including the smelting, beneficiation, reduction, refining, calcining or gasification of the mineral resource in which case activity 6 in Listing Notice 2 applies.</p>	<p>Approx. 49 600 Ha</p>	<p>X</p>	<p>Listing Notice GNR 327, Activity 20</p>
<p>The development of a road—</p> <p>(i) [a road] for which an environmental authorisation was obtained for the route determination in terms of activity 5 in Government Notice 387 of 2006 or activity 18 in Government Notice 545 of 2010; or</p>	<p>Access roads and internal road network.</p>	<p>X</p>	<p>Listing Notice GNR 327, Activity 24</p>

<p>(ii) [a road] with a reserve wider than 13,5 meters, or where no reserve exists where the road is wider than 8 metres;</p> <p>but excluding a road—</p> <p>(a) [roads] which [are] is identified and included in activity 27 in Listing Notice 2 of 2014;</p> <p>(b) [roads] where the entire road falls within an urban area; or (c) which is 1 kilometre or shorter.</p>			
<p>The decommissioning of any activity requiring - (i) a closure certificate in terms of section 43 of the Mineral and Petroleum Resources Development Act, 2002 (Act No. 28 of 2002); or (ii) a prospecting right, mining right, mining permit, production right or exploration right, where the throughput of the activity has reduced by 90% or more over a period of 5 years excluding where the competent authority has in writing agreed that such reduction in throughput does not constitute closure.</p>	<p>Obtain closure certificate after prospecting activities have been completed, if necessary.</p>	<p>X</p>	<p>Listing Notice GNR 327, Activity 22</p>
<p>The development and related operation of facilities or infrastructure, for the storage, or for the storage and handling, of a dangerous good, where such storage occurs in containers with a combined capacity of 80 cubic metres or more but not exceeding 500 cubic metres.</p>	<p><500 m³</p>	<p>X</p>	<p>Listing Notice GNR 327, Activity 14</p>
<p>The expansion of infrastructure for the bulk transportation of water or storm water where the existing infrastructure— (i) has an internal diameter of 0,36 metres or more; or (ii) has a peak throughput of 120 litres per second or more; and (a) where the facility or infrastructure is expanded by more than 1 000 metres in length; or (b) where the throughput capacity of the facility or infrastructure will be increased by 10% or more;</p>	<p>≈2 km</p>	<p>X</p>	<p>Listing Notice GNR 327, Activity 45</p>
<p>The expansion of facilities or infrastructure for the transmission and distribution of electricity where the expanded capacity will exceed 275 kilovolts and the development footprint will increase.</p>			<p>Listing Notice GNR 327, Activity 47</p>
<p>The storage of hazardous waste in lagoons excluding storage of effluent, wastewater or sewage.</p>		<p>X</p>	<p>Category B(1)</p>

The treatment of hazardous waste in lagoons, excluding the treatment of effluent, wastewater or sewage.		X	Category B(5)
The construction of a facility for a waste management activity listed in Category B of this Schedule.		X	Category B(10)

National Environmental Management: Waste Act, 2008 (Act No. 59 of 2008) - Government Notice Regulation 921 – 29 November 2013; Category A(15); Category B(1), B(5) and B(10).

National Water Act, 1998 (Act No. 36 of 1998) – section 21(a): Taking water from a water resource and section 21(b): Storing water, section 21(c): Impeding or diverting the flow of water in a watercourse, section 21(i): Altering the bed, banks, course or characteristics of a watercourse; section 21(g): disposing of waste in a manner which may detrimentally impact on a water resource; section 21(j): Removing, discharging or disposing of water found underground if it is necessary for the efficient continuation of an activity or for the safety of people.

An application for Integrated Environmental Authorisation has been lodged with the Department of Mineral Resources and Energy, Northern Cape. This Integrated Environmental Authorisation application process is being undertaken in a two-phased approach as written in this section in order to give members of the public to review and partake in the process and to enable the competent authority to make an informed decision pertaining to the application under discussion:

- Phase 1 - Scoping Report (SR) and Plan of Study for Environmental Impact Assessment; and
- Phase 2 - Environmental Impact Assessment (EIA).

3.1.1 Scoping Report Phase (SRP)

The Scoping Report Phase seeks to describe the receiving environment and how the environment may be affected by the proposed development. The desktop studies that are conducted making use of literature review mechanisms and preliminary investigations by means of brief site visit, was used to highlight and assist in the identification of potential significant socio-economic and environmental impacts associated with the proposed development.

The public participation process that is underway will held to identify any additional issues due for consideration in the course of current studies. Public Participation Process is a continuous process.

Comments made, input submitted and / or questions asked during the Public Participation process are going to be considered in the compilation of the EIA relating to the proposed project.

All issues raised during the Scoping Phase of the current study underway will be capture in the Final Scoping Report and in the EIA report, if applicable.

The Scoping Report Phase aims to address the following:

- Description of the site selected for the proposed prospecting for mineral resources development;
- Identification of potential significant socio-economic and environmental impact (both positive and negative); and
- Conduct public participation process widely to ensure that Interested and Affected Parties (I&AP) become part of the Environmental Authorisation process and that the issues they raise are recorded and form part of the EIA process.

Additionally, the Scoping Phase seeks to identify any fatal flaws, site alternatives, site layout alternatives (if applicable) and proposes mitigation alternatives to be evaluated and investigated during the EIA phase of the studies underway. A list of proposed specialist studies to be conducted in relation to the proposed project include biophysical and cultural aspects

3.1.2 Environmental Impact Assessment Phase / Study

The Constitution of the Republic is the supreme law of the land (South Africa). The Constitution provides the legal framework for legislation regulating any matters or conduct in South Africa, including environmental management in general. This regulating of matters has to be interpreted in accordance with the purport for the Bill of Rights. In order to give effect to section 24 of the Constitution, a nation framework (NEMA) for regulating environmental management was enacted. The NEMA sets out a number of principles (Chapter 1, Section 2) to give guidance to developers, private land owners, members of public and authorities.

The Environmental Impact Assessment phase is going to be undertaken in order to aim to achieve the following:

- To give effect to the proposed Scoping Phase approach, inclusive of considered inputs from Interested and Affected Parties;
- To investigate overall potential impacts;

- To provide an overall assessment of the social-economic and environmental impacts pertaining to the area of application;
- To undertake a detailed assessment of the preferred site/s in terms of environmental criteria including the rating of significant impacts;
- To identify and recommend appropriate mitigation measures (to be included in the Environmental Management Programme) for potentially significant environmental impacts; and
- To undertake a wide public participation process that is transparent and inclusive to ensure that I&AP issues and concerns are duly considered in the EIA process that is underway.

3.2 Details of Consultant and Environmental Impact Assessment Practitioner

The particulars of the Consultant and EAP(s) involved in this study are presented in Table 2.

Table 2: Details of the Consultant and EAP

Name of Consultancy:	Thaya Trading Enterprise CC
Name of EAP	Kwindla Nobaza
Physical Address	9705 Eerste Laan Rooisand Kathu 8446
Contact Number:	071 959 9207
E-mail	kwindla.nobaza@thayatrading.co.za / info@thayatrading.co.za
Contact Person:	Kwindla Nobaza
Title	Prospecting Right Application for Diamonds and Iron and Manganese Ores on the Farm Gamohaan No. 438, near Kuruman, John Taolo Gaetsewe District, Northern Cape, South Africa
Experience:	<p>More than Four (4)</p> <p>Kwindla, the registered EAP is the founding member of Thaya Trading Enterprise. He completed an M. Sc. degree in Chemistry with the University of Johannesburg; currently, he is studying towards an LLB degree through UNISA. The Director of Thaya Trading Enterprise has completed courses with the University of South Africa, such as: "Interpretation of Statutes" and "Environmental Law". Based on completion of the course on Interpretation of Statutes, it is noteworthy that the company (TTE) is under the leadership of an individual who understands the contextual approach to interpretation of all pieces of legislation in South Africa. That includes the Mine Health and Safety Act; Mineral and Petroleum Resources Development, 2002 (Act No. 28 of 2002); National Environmental Management Waste Act, 2008 (Act No. 59 of 2008), National Water Act, 1998 (Act No. 36 of 1998) [as amended], among others.</p> <p>Kwindla is registered as a Professional Natural Scientist with the South African Council for Natural Scientific Professions. He has been involved in EIAs for more than four (4) years.</p>

3.3 Structure of this Scoping Report

The piece of work that is presented herein is written in accordance to the Guidelines as provided in Government Notice Regulation 326 of the EIA Regulations, 2017 as summarised in Table 3. This Scoping Report is compiled in accordance with *Appendix 2* of Government Notice Regulation of the EIA Regulations, 2017.

Table 3: Structure of Scoping Report

SR Requirements according to Section 21(3) of GNR 326	Section of this Report
(a) details of (i) the EAP who prepared the report; and (ii) the expertise of the EAP to carry out scoping procedures	Section 3.2
(b) the location of the activity, including – (i) the 21 digit Surveyor General code of each cadastral and land parcel; (ii) where available, the physical address and farm name; (iii) where the required information on (i) and (ii) is not available, the coordinates of the boundary of the properties	Section 8.2 & Figure 11
(c) a plan which locates the proposed activity or activities applied for at an appropriate scale, or, if it is – (i) a linear activity, a description and coordinates of the corridor in which the proposed activity or activities is to be undertaken; or (ii) on land where the property has not been defined, the coordinates within which the activity is to be undertaken	Section 1.4
(d) a description of the scope of proposed activity, including – (i) all listed and specified activities triggered; (ii) a description of the activities to be undertaken, including associated structures and infrastructure	Section 4.2
(e) a description of the policy and legislative context within which the development is proposed including and identification of all legislation, policies, plans, guidelines, spatial tools, municipal development planning frameworks and instruments that are applicable to this activity and are to be considered in the assessment process	Section 4.2
(f) a motivation for the need and desirability for the proposed development including the need and desirability of the activity in the context of the preferred location	Section 2
(g) a full description of the process followed to reach the proposed preferred activity, site and location within the site, including – (i) details of the alternatives considered; (ii) details of the public participation process undertaken in terms of regulation 41 of the Regulations, including copies of the supporting documents and inputs; (iii) a summary of the issues raised by I&AP, and an indication of the manner in which the issues were incorporated, or the reasons for not including them; (iv) the environmental attributes associated with the alternatives focusing on the geographical, physical, biological, social, economic, heritage and cultural aspects;	Section 5

<ul style="list-style-type: none"> (v) the impacts and risks identified for each alternative, including the nature, significance, consequence, extent, duration and probability of the impacts, including the degree to these impacts – <ul style="list-style-type: none"> (aa) can be reversed; (ab) may cause irreplaceable loss of resources; and (ac) can be avoided, managed or mitigated; (vi) the methodology used in determining and ranking the nature, significance, consequences, extent, duration and probability of potential environmental impacts and risks associated with the alternatives; (vii) positive and negative impacts that the proposed activity and alternatives will have on the environment and on the community that may be affected focusing on the geographical, physical, biological, social, economic, heritage and cultural aspects; (viii) the possible mitigation measures that could be applied and level of residual risk; (ix) the outcome of the site selection matrix; (x) if no alternatives, including alternative locations for the activity were investigated, the motivation for not considering such; and (xi) a concluding statement indicating the preferred alternatives, including preferred location of the activity 	
SR Requirements according to Section 21(3) of GNR 326	Section of this Report
<ul style="list-style-type: none"> (h) a plan of study for undertaking the environmental impact assessment process to be undertaken, including – <ul style="list-style-type: none"> (i) a description of the alternatives to be considered and assessed within the preferred site, including the option of not proceeding with the activity; (ii) a description of the aspects to be assessed as part of the environmental impact assessment process; (iii) aspects to be assessed by specialists; (iv) a description of the proposed method of assessing the environmental aspects, including a description of the proposed method of assessing the environmental aspects including aspects to be assessed by specialists; (v) a description of the proposed method of assessing duration and significance; (vi) an indication of the stages at which the competent authority will be consulted (vii) particulars of the public participation process that will be conducted during the environmental impact assessment process; (viii) a description of the tasks that will be undertaken as part of the environmental impact assessment process; and (ix) identify suitable measures to avoid, reverse, mitigate or manage identified impacts and to determine the extent of the residual risks that need to be monitored. 	Section 11
<ul style="list-style-type: none"> (i) An undertaking under oath or affirmation by the EAP in relation to – <ul style="list-style-type: none"> (i) The correctness of the information provided in the report; (ii) The inclusion of comments and inputs from stakeholders and I&APs; and (iii) Any information provided by the EAP to I&APs and any responses by the EAP to comments or inputs made by I&APs 	
<ul style="list-style-type: none"> (j) An undertaking under oath or affirmation by the EAP in relation to the level of agreement between the EAP and I&APs on the plan of study for undertaking the environmental impact assessment 	

(k) Where applicable, any specific information required by the competent authority; and	
(l) Any other matter required in terms of section 24 (4)(a) and (b) of the Act	

3.4 The location of the activity, including-

3.4.1 The 21-digit Surveyor General code of each cadastral and land parcel

Information pertaining to the proposed project is presented in Table 4.

Table 4: Property Information

Farm Name:	Farm Gamohaam No. 438, within the Administrative District of John Taolo Gaetsewe, Northern Cape, South Africa.
Application area (Ha)	Approximately 2 600 Ha
Magisterial district:	Kuruman, John Taolo Gaetsewe District Municipality, Northern Cape
Distance and direction from nearest town	The application area is situated approximately 46 km Est of Kathu and about 13 km and Northwest of Kuruman, Northern Cape, South Africa.
21-digit Surveyor General Code for each farm portion	C041000000004380000 C041000000004380001 C041000000004380002

3.4.2 where available, the physical address and farm name

Please refer to section 3.4.1.

3.4.3 where the required information on 3.4.1 and 3.4.3 is not available, the coordinates of the boundary of the properties

Please refer to section 3.4.1. and Figure 3.

4 a plan which locates the proposed activity or activities applied for at an appropriate scale, or, if it is

–

The proposed Project is located (Figure 2) within an area whose zoning has not been requested for at the moment. The area of application is not located within a protected area and is therefore relatively less threatened. The findings of the proposed Biodiversity Assessment, if any, to be conducted will provide guidance of what trees are protected within the application area

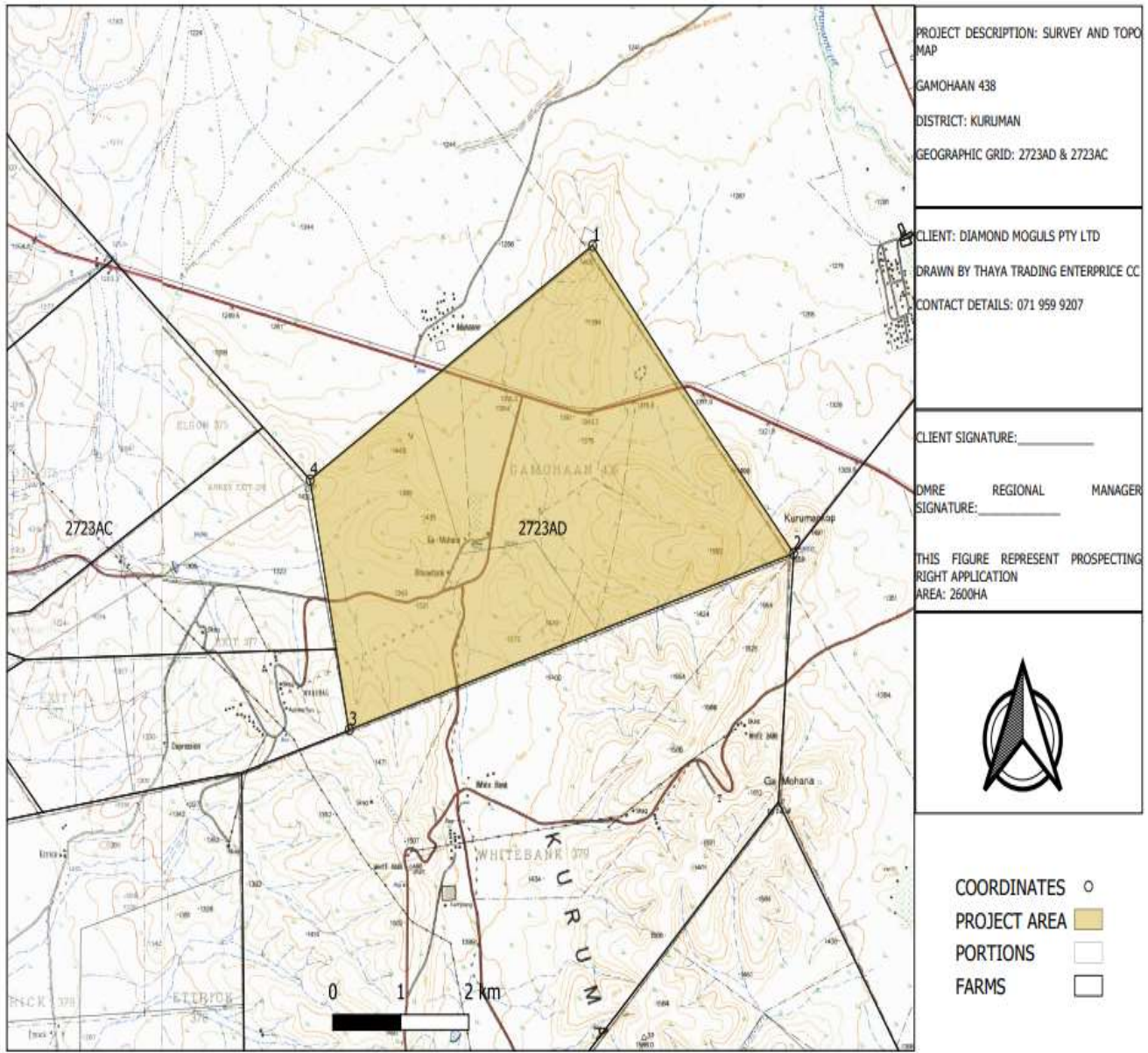

Figure 2: Project Application Area

Locality of the proposed development is depicted in Figures 2 and 3.

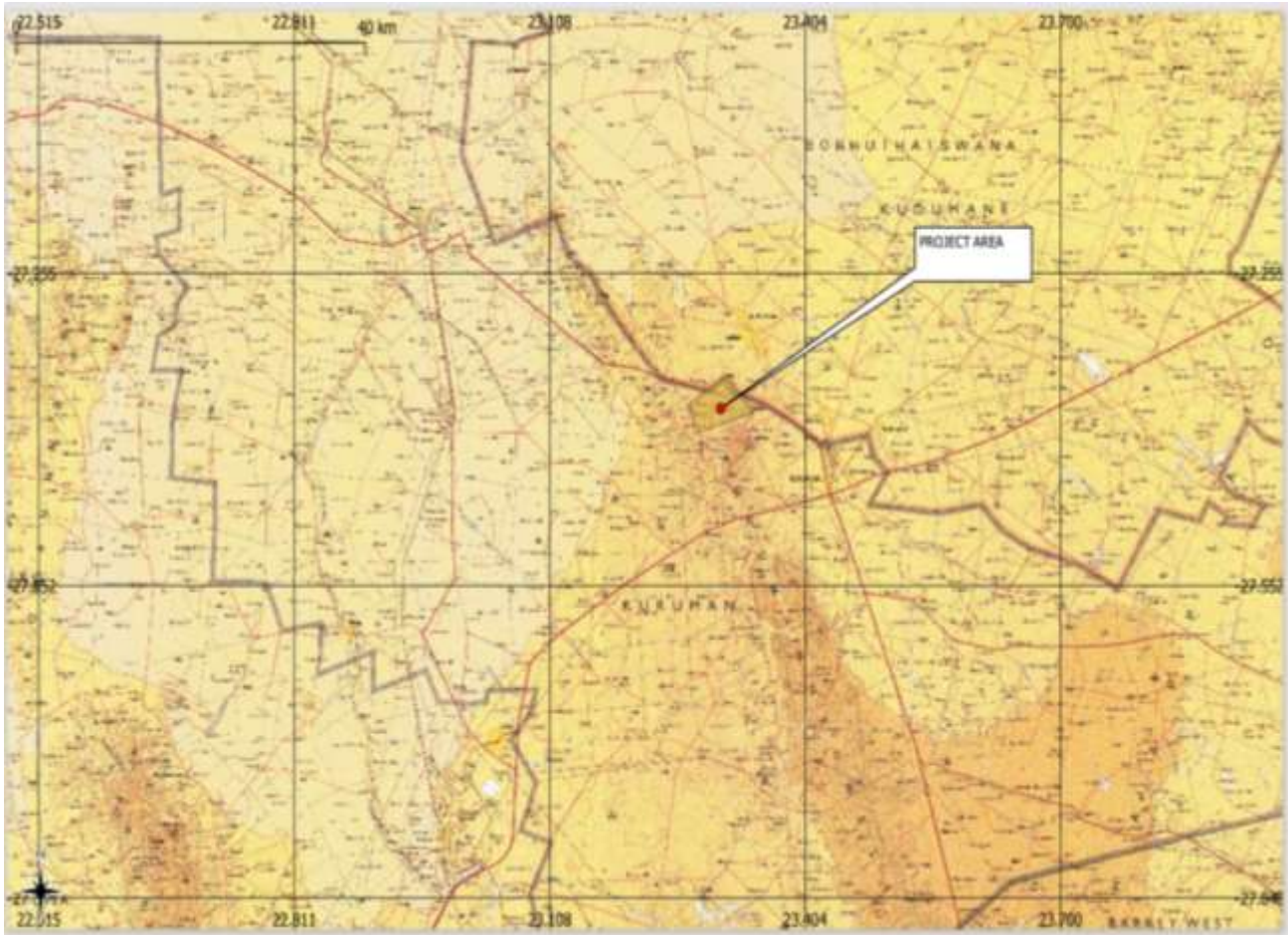

Figure 3: Locality Map of John Taolo Gaetsewe District

4.1 A linear activity, a description and coordinates of the corridor in which the proposed activity or activities is to be undertaken; or

Activities are going to be undertaken on the Prospecting Right application area Farm Gamohaan No. 438, near Kuruman, Northern Cape.

4.2 On land where the property has not been defined, the coordinates within which the activity is to be undertaken

Please refer to section 3.

5 Project Description

Diamond Moguls (Pty) Ltd lodged applications with the Department of Mineral Resources and Energy for prospecting right in terms of the Mineral and Petroleum Resources Development Act, 2002 (Act No. 28 of 2002) and an Integrated Environmental Authorisation in terms of both the National Environmental Management Act, 1998 (Act No. 107 of 1998) and the National Environmental Management: Waste Act,

2008 (Act No. 59 of 2008). In response to the acceptance of the MPRDA application, the first phase of the Environmental Impact Assessment (EIA) process is underway. As part of the first phase of the EIA process to investigate the impact that the proposed development is going to have on the environment, this piece of work (Scoping Report) is prepared and subjected to a public participation process. In order to support the proposed development and associated activities, and processes, an Integrated Water Use License Application has to be lodged with the Department of Human Settlements, Water Sanitation (DHSWS) in terms of the National Water Act, 1998 (Act No. 36 of 1998). It is envisaged that the project team is going to abstract water from underground on site. In an event, a different arrangement other than the one envisaged is made, both the Responsible Authority (DHSWS) and the Competent Authority (DMRE) will be consulted.

5.1 Description of Planned Non-Invasive Activities

High resolution satellite images will be studied and used to geologically map the application area. Contacts between various lithologies will be mapped and specific attention will be given to delineate and define areas underlain by alluvial gravels or Kimberlites, Iron and Manganese Ores.

A site investigation of the target areas will be undertaken to identify infrastructure and determine any potential problems that may need to be addressed.

Analytical Desktop Study

The project Geologist monitors the programme, consolidates and processes the data and amends the programme depending on the results. This is a continuous process throughout the programme and continues even when no prospecting is done on the ground.

Each physical phase of prospecting is followed by desktop studies involving interpretation and modelling of all data gathered. These studies will determine the way the work programme is to proceed in terms of activity, quantity, resources, expenditure and duration.

A GIS based database will be constructed to capture all exploration data.

5.2 Description of Planned Invasive Activities

In accordance with the National Environmental Management Act of 1998 (Act No. 107 of 1998) and the National Environmental Management: Waste Act of 2008, Diamond Moguls (Pty) Ltd submitted applications to the Department of Mineral Resources and Energy for a prospecting right under the Mineral

and Petroleum Resources Development Act of 2002 (Act No. 28 of 2002) and an Integrated Environmental Authorization (Act No. 59 of 2008). As a result of the MPRDA application being accepted, the Environmental Impact Assessment (EIA) process has begun. This work (Scoping Report) is compiled and made available to the public as part of the first phase of the EIA process to look into the potential environmental effects of the proposed development.

In addition, and according to the National Water Act of 1998 (Act No. 36 of 1998) an Integrated Water Use License Application must be filed with the Department of Human Settlements, Water Sanitation (DHSWS) in order to support the proposed development and related processes. An on-site water abstraction from the ground is envisaged by the project team.

It is also advised that both the Responsible Authority (DHSWS) and the Competent Authority (DMRE) will be consulted in the event that an alternative arrangement is formed to the one that was originally planned.

Description of Planned Non-Invasive Activities

The application area will be geologically mapped using high resolution satellite imagery. A special focus will be placed on defining and delineating the areas underlain by alluvial gravels or kimberlites, Iron and Manganese ore and contacts between different lithologies will be mapped.

The target areas will undergo a site analysis to identify infrastructure and identify any potential issues that may need to be addressed.

Analytical Desktop Study

The project geologist monitors the program, compiles and processes the data, and modifies the program as needed in response to the results. Even when there is no prospecting being done on the ground, this process is ongoing throughout the program.

Following each physical stage of prospecting, desk studies are conducted that involve the interpretation and modelling of all the data gathered. These studies will determine the activity, quantity, resources, expenditure, and duration of the task programmed and all the exploration data will be gathered in a GIS-based database.

Description of Planned Invasive Activities

During the initial stages of the planned project, Drilling, Pitting and Trenching are going to be undertaken.

The proposed development is going to follow a stepwise process. Pitting should take place only after results have been obtained from drilling exercise undertaken. This is going to form part of the Environmental Impact Assessment Report to be submitted to the Department of Mineral Resources and Energy. After the right is obtained, if issued, the planned site visit will be undertaken. The developer must conduct desktop studies to locate target areas and the area for mobile and / or immobile infrastructure to be built and to identify potential risks. At Operational Phase, the proponent must use of drill rigs to drill for ore body, gravel and to determine the quality of the minerals, gravel, iron and manganese ores (with a maximum of six (6) drillholes at a time, with concurrent rehabilitation, thereafter, another six drillholes). Percussion drilling is going to be undertaken. If a need arises, geological core boreholes will be drilled over the prospecting area. All borehole cores will be logged and the potentially viable seam intersections sent for initial raw analysis to determine value. If the quality of the Iron and manganese ore seams warrant further investigation, washability analysis of the ore seams will be undertaken. All geological prospecting boreholes will be surveyed and plotted on the base plan. Any other right holder on the study area or in the vicinity thereof may be notified of the results obtained from this process, if applicable. Appropriate equipment and prospecting methods must be utilized in order to promote sustainable development. Furthermore, the proponent must determine quality and quantity ore. A geomagnetic survey may be undertaken to determine the presence of igneous intrusions. This survey will consist of traverses using a hand-held magnetometer. A GPS will be used to record the data point locations. Boreholes will be drilled at pre-determined sites on the property. A 60mm diameter (min.) core drill will be used to drill the geological boreholes. The time required is less than 48 months to complete all core drilling and rehabilitation of the core drilled holes. The cored boreholes will be drilled to the base of the Dwyka sediments among others, if applicable. All boreholes will be logged with descriptions of all layers intersected. All the commodities, Iron and Manganese ore seams intersected will be sampled and analyzed to determine the grade of the ore. A geological report will be compiled accordingly in respect of the commodities, Iron and Manganese ore resources in accordance with SAMREC Code. Small diameter borehole core drilling enables the evaluation of both the physical continuity of the Iron ore seam(s) and the quality continuity of the Iron and Manganese ore. The borehole core data shall be used for structural evaluation, ore seam correlation, ore quality analyses and geotechnical evaluation. For adequate sample volume, the borehole core diameter shall be not less than 60 mm in diameter in the case of Iron and Manganese ore samples submitted for washability analysis. A minimum borehole core diameter of 49 mm is acceptable for Iron ore samples for washability and raw proximate analyses.

For reliable Iron and Manganese ore resource evaluation, the core recovery shall be in excess of 95 % within the Iron and Manganese ore seam and all core recovery information shall be properly documented.

The spacing of small diameter borehole core holes for geological studies depends on the Iron and Manganese ore deposit type, whether thick interbedded seam or multiple seam deposit types. The spacing between boreholes shall be decreased appropriately where significant Iron and Manganese ore quality changes occur in structurally complex areas and along the ore seam sub-outcrop.

Site preparation

Site clearance – site is going to be cleared of some vegetation and leveled. Firebreaks are also going to be prepared.

Topsoil removal – minimal topsoil is going to be removed and piled adjacent to point of removal.

Water supply – water is going to be supplied using water cart or any other authorized water use for purposes of drilling, sampling, processing (if applicable).

Rig / Drill preparation

Percussion drilling may take place. Also, diamond core drilling is recommended. Top of hole lined with steel casing to suitable depth, if required. Carbon footprint is minimized during this process.

Mobile ablution and camping facilities are going to be utilized. Lockable facilities for hazardous substances and bunded areas for small scale maintenance will be provided. Small sumps (about 0.25 m³ in volume) will be excavated. These sumps may be utilized to recycle water used during the drilling process. The drill area is going to be cordoned off with barricade tape and labelled with appropriate signage as a measure to control access.

Drilling

Core drilling is going to commence. This process uses water for cooling, using diesel engine as a power source, with an estimated usage of about 500 litres per session.

Core material is removed as the drilling progresses, sampling is conducted and samples are removed from site and sent to the Laboratory for analysis. The core material is kept for future reference.

Decommissioning and Rehabilitation

Upon completion of the drilling process, the drill rig and hydrocarbon containers are going to be removed from site.

The water used during the drilling process is going to be pumped into a waste water tanker and disposed of on an approved site.

The sumps, if any, are going to be backfilled and compacted.

All mobile machinery is going to be taken off site.

All barricades are going to be removed.

All disturbed areas (including roads) are ripped and allowed to return to the natural state. Seeding is not going to be undertaken at this small scale as experience has shown that the natural process returns the site to its former state within a seasonal cycle. In an event this does not happen, the disturbed area will be seeded.

Ablution facilities are going to be used for doing laundry and washing of body. Mobile toilets are going to be serviced by the local supplier. Waste disposal is going to be conducted at an authorized facility.

Monitoring

Monitoring of site is going to be undertaken on a quarterly basis to ensure returning of site to reasonably practicable state.

Geophysical Survey

A handheld proton Magnetometer will be used to undertake the Geophysical survey. Readings will be taken every 20 meters (minimum) along traverse lines. A base station will be used to record any changes in the earth magnetic field during the field survey.

Field data will be obtained based on the principles and guidelines as outlined in the Geophysical Field Manual for technicians – the Magnetic Method, SAGA.

Extrapolated baseline data will be obtained from the available geological data on the surrounding farms. This data will be incorporated with the geophysical survey and form the basis for the drilling phase. A geological report will be compiled stating the Iron and Manganese ore resources in accordance with the SAMREC Code.

Data collection from drilling programme

The recovered core will be described geologically in respect of the lithological horizons intersected and the Iron ore seam cores will be described and sampled in economic units according to the recognisable ore horizons that may be present in the intersections.

The sampled core will be analysed at the Laboratory, an established and accredited Iron ore laboratory for the following:

- Raw Iron ore analysis - Proximate, CV and Sulphur
 - Each sample will be analyzed for Moisture, CV etc.

- Further specialized analysis may be required such as:
 - Ash fusion temperature;
 - Abrasive index;
 - Hardgrove Grindability Index;
 - Ash analysis;
 - Ultimate analysis.

Data processing

The first, second and third phase data collection in this manner will be structured by the technical consultants and then processed and modeled electronically, together with results obtained from the non-invasive activities. A set of geological data will be produced at this stage.

It will be utilized to calculate the resource quantity, qualities and to model the conceptual mining program.

The economic studies required to determine the feasibility of the project will be carried out and the feasibility study finalized.

If the study proves to be feasible, the applicant will proceed with the Mining Right Application.

Bulk sampling is a sampling technique

Volumes of the mineral to be tested

About 5 Pits will be excavated with the dimensions as written in Table 2 in order to determine whether there are any commodities of interest underground. It is estimated that an average 3 – 70m of overburden (calcrete, dolomite, waste rock and soil) will be removed before accessing the ore body which is expected to host diamonds, Iron and Manganese ores. The trenches will be 200 m x 100 m x 200m deep. We calculated the volume of gravel on 50m and if all 5 pits are going to be excavated an average of 1 000 000m³ per pit will be tested.

Why will they be tested?

The Iron and Manganese ore will be tested. The testing will be conducted at an analytical laboratory. Kimberlitic material and diamondiferous gravels will be tested to determine a grade (carats per hundred tonne) and value (US\$ per carat). The closest Iron and Manganese ore operations together with the

nearby diamond operations may be utilised to processing of material. Alternatively, the applicant may have to utilise processing plant to be placed on site.

Where will they be tested?

All bulk sampling activities will take place on site or out of site. Herewith follows a description of the process: -

The planned bulk sampling technique is that of a typical South African diamond, iron and manganese ore operations and may have to include mining of kimberlite. A part of the planned prospecting method is a strip-mining process with oversize material from the gravel scalping and the tailings from the plant, being used as a backfill material prior to final rehabilitation. The Ores and Gravels are excavated, loaded and transported to the nearby treatment facility using articulated dump trucks. The access to the various trenches will be provided by a haul road to the screening and processing plants. The operation is to be conducted using conventional open pit mining equipment comprising two articulated dump trucks supported by appropriate excavators and a front-end loader. A possibility of establishing underground channels and shafts will be investigated and explored, as it may happen at later stages of this proposed development, that underground operations become necessary. The vegetated soil overlying the planned trenches is stripped prior to excavation of the ores and gravel and stockpiled on a dedicated dump to be used for rehabilitation purposes at a later stage. The ores and gravel is loaded with 60-t excavators onto ADT's. Ore is hauled to the screening plant. As an integral part of the bulk sampling processes, backfilling will take place continuously. The operation is to be conducted using conventional open pit mining equipment at the beginning:

Earthmoving and ancillary equipment

4 x Excavator

4 x Front-end Loader

4 x Articulated Dump Trucks

1 x Doser

2 x Water Trucks

1 x Bulldozer

1 x 16ft-Rotary Pan

1 x Jig/DMS/Sinter Plant/Rotary Plant

Crushers and Screens

2 Power Generators

Drill Rigs

Screen

Crushers

Utility vehicles and small tools

Diamond recovery unit with Flow sort Machines, Plant, and recovery, crushing and screening equipment

Kimberlitic material and Gravels are loaded onto a vibrating grizzly and the +85mm oversize material is discarded back into the open pit (about 25% reduction). The remaining -85mm fraction is loaded into a 16-foot rotary pan with a treatment capacity of 100 tph. A magnetic separator is used to extract some of the heavy banded iron stones. Tracer tests are done regularly to ensure that the pans are operating at the correct density. Approximately 2.5 tonne of concentrate is tapped from the pan every hour and transported in locked containers to the final recovery unit. The final recovery unit consists of a holding bin, sizing screen, sizing bins and one state of the art Flowsort X-ray recovery unit which recover diamonds from the +2mm to -32mm size fraction. Final sorting of the X-ray concentrate will be done manually. Rehabilitation will take place continuously and at any stage only one trench will be open.

To whom they will be disposed of:

At an expected grade of 2 carats per hundred tonnes, 8 800 carats could be recovered from the kimberlitic material and gravels. Diamonds will be sold at a reputable diamond tender house in Kimberley or international communities that are affiliated to the Kimberly Process to determine an average US\$ carat value for the diamonds.

Another part of Prospecting Method will include site preparation

Site preparation includes the clearing of vegetation and topsoil stripping. Topsoil is stockpiled, for later use in rehabilitation.

5) Earthworks

Following site preparation all topsoil and some waste rock is dozed and stockpiled separately for re-use for rehabilitation activities

Drilling and blasting

Some of the topsoil, overburden material will be removed. The waste rock is drilled and blasted in benches until the economic ore body is exposed. This is done in a manner that is of high quality, effective and efficient. Best industry practices are to be employed in the process. Similarly, drill and blast methods are used to break the ore with careful attention being paid to avoiding contamination of the ore with overburden material and waste.

Blasting will occur only if deemed necessary. All the recommended best practices will be observed should blasting be deemed necessary at any stage of this proposed development.

Removal of waste rock

Broken waste rock is loaded by excavator and hauled by auxiliary dump trucks to the waste dumps where it is tipped.

Rehabilitation

Once the open pit and trench reach a steady state, on-going rehabilitation of the excavated areas using methods such as concurrent backfilling will occur as prospecting activities advance. In this regard, waste rock will be used to backfill the pit voids (once there is enough space to dump)

MINERAL PROCESSING METHOD

Primary crushing and screening

ROM is delivered to the primary crushing and screening plant using auxiliary dump trucks. The primary crushing and screening plant are used to reduce the size of the ore to fractions required by the downstream plant processes. ROM that has been subjected to the primary crushing and screening plant is stockpiled prior to being sent to the secondary crushing and screening plant using machinery or conveyor for further re-sizing. Dust suppression using appropriate techniques should be employed at all crushing and screening locations.

Secondary crushing and screening

The secondary crushing and screening plant is used to size the ore according to product specifications. The final product from the secondary crushing and screening plant is stockpiled at one of the product

stockpile areas or the crushed ROM stockpile. The processed ore that is going to be stockpiled may vary between -6+1 mm and -75 + 6 mm. Different individual fractions may be stockpiled separately. The final product is loaded out of site to be sold to local and international markets for further beneficiation. Front end loaders or equivalent loaders are to be used to load product out of site.

Superfine waste material will be re-used as topsoil for rehabilitation and re-vegetation purposes.

Tertiary crushing and screening (to be sent to nearby mining operations for further processing)

The tertiary crushing and screening section (- 40, +6 mm material) will be used to prepare the ore for sinter plant feed. High grade product will be stockpiled at the tertiary product stockpile prior to being sent to the sinter plant. Manganese that is below the required grade from the tertiary crushing and screening plant will be stockpiled at a low-grade stockpile prior to being sent to the Dense Medium Separator (DMS) for further processing. Any fines material (-1 mm) produced at the tertiary crushing and screening plant will be sent to the thickener for disposal to the tailings dam

Sintering (to be sent to nearby mining operations for further processing)

In the sinter plant, ore will be sintered by the application of heat, to agglomerate it and to increase the manganese content (by burning off the carbonaceous material). Raw materials will be mixed with the manganese ore in a rotating mixing pan prior to agglomeration in a rotary drum. The agglomerated material will be fed into the sinter furnace on a steel belt. The sinter furnace is a multi-compartment oven that is ignited with gas or heavy fuel oil. The front compartments will be used for drying, ignition and sintering. The back compartments will be for cooling. Gas emissions will be scrubbed in cascade scrubbers to remove most of the particulates and pollutants. The dirty scrubber water will be re-cycled in the thickener plant. Dust emissions will be captured in bag filters and recycled into the sinter feed. The final product will be stockpiled on the product stockpile prior to being loaded out of site to be sold to third parties.

Dense medium separation (to be sent to nearby mining operations for further processing)

Prior to the sintering stage, manganese ore that is below the required grade (- 6 + 1 MM) can be beneficiated using dense medium separation, effectively upgrading the ore. Using density differential between manganese and waste; the material will be sent to the sinter feed stockpile prior to being sent to the sinter plant while the waste will be disposed onto the temporary discard dump. Samples will be sent to a laboratory for analysis whilst a backup samples is stored.

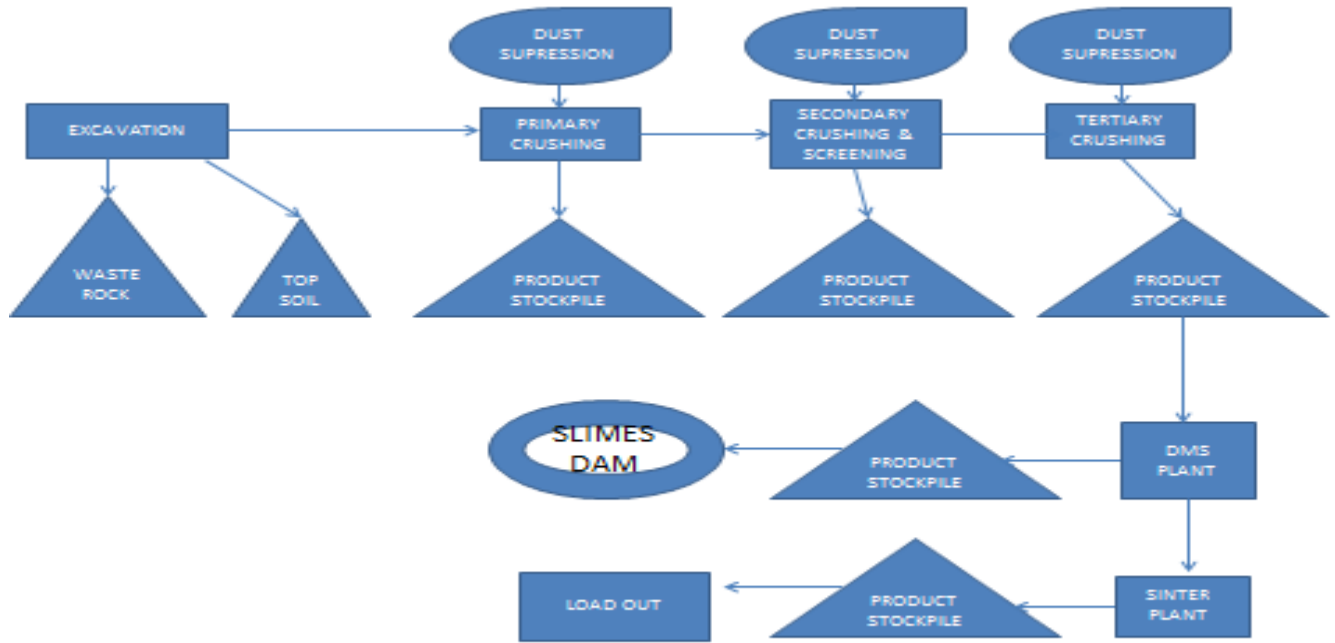

Figure 4: Schematic representation of the planned process flow

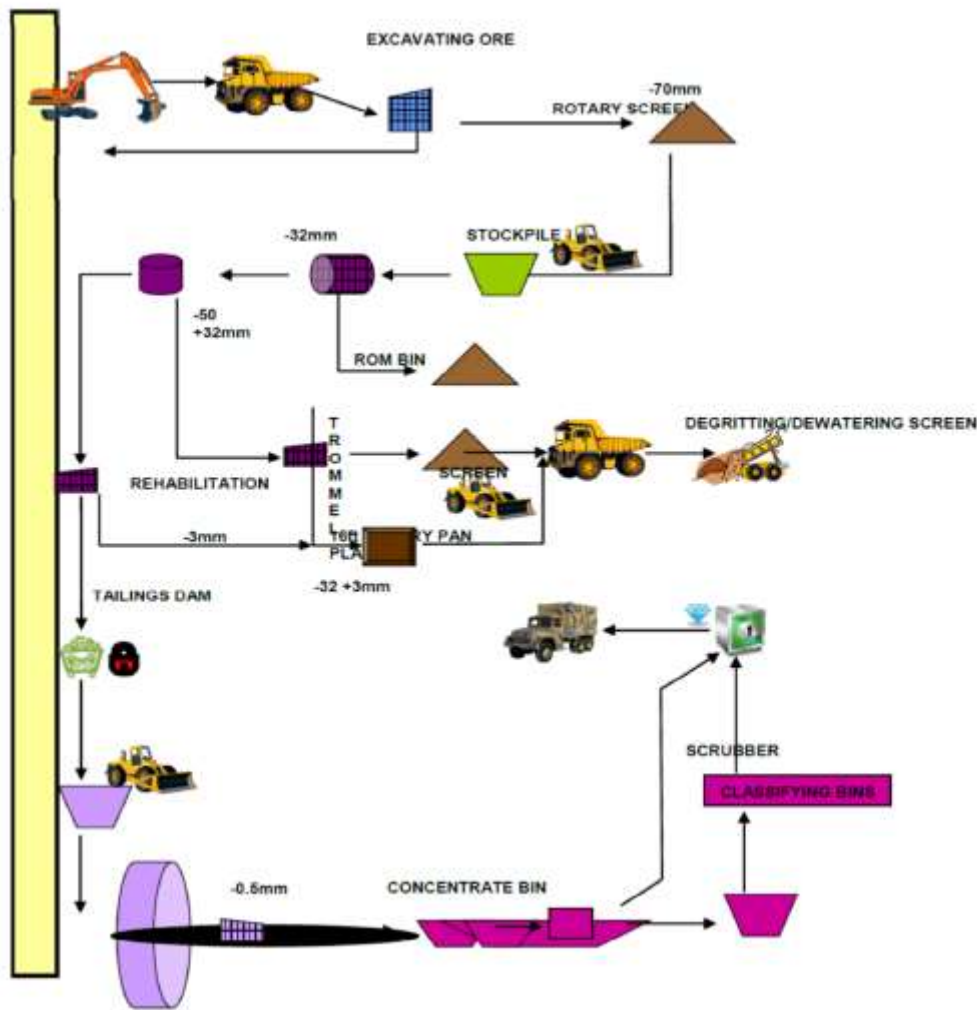

Figure 5: Schematic representation of the planned process flow for diamond processing.

5.2.1 Construction Phase

The Construction Phase entails the following:

- Preparing the area to cater for a campsite to accommodate personnel and infrastructure relevant to the planned mining, crushing, recovering activities, among others.
- Site clearance (where necessary), construction of earthworks and removal of rubble;
- Deposit waste rock and overburden material;
- Topsoil stripping and stockpile establishment;
- Construction of firebreaks and fire hydrants;
- Construction of pollution control facilities, if necessary;
- Construction of storm water management facility in order to limit the amount of water that enters the pits;
- Establish Waste Management Facilities, if necessary; and
- Establish access roads and internal temporary road network.

5.2.2 Operational Phase

The Operational Phase entails the following:

- Drilling, Pitting and Trenching, Excavation, Crushing, Screening, Sorting, Load and Haul of material;
- Operation of equipment and machinery;
- Use of Water and Hydrocarbons;
- Use of pollution control and waste management equipment and machinery;
- Maintenance of equipment and machinery;
- Pitting and trenching;
- Dewatering of pits and trenches, if necessary; and
- Concurrent Backfilling, Closure and Rehabilitation

5.2.3 Decommissioning Phase

Mobile equipment is going to be used in these operations. When mobile infrastructure is used, the decommissioning phase is going to be straight forward as the infrastructure would be transported away from site. It is worth mentioning that the schedule of rehabilitation is going to be phased to run in parallel with the mining and crushing activities to ensure 'pain-free' rehabilitation ultimately. Removed and relocated species are going to be planted again or returned to their habitat.

Table 5: Bulk Sampling Activities

ACTIVITY		DETAILS		
Number of pits/trenches planned		5 pits and 100 trenches		
	Number of pits/trenches	Length	Breath	Depth
	5/100	200 m	100 m	200 m
Locality		See figure 1		
Volume Overburden (Waste)		$\leq 1\,000\,000\text{ m}^3$		
Volume Ore		$\approx 3\,000\,000\text{ m}^3$		
Density Overburden		To be determined during Prospecting Activities.		
Density Ore		$\approx 5.15\text{ g/cc}$; to be determined during Prospecting Activities.		
Phase when bulk sampling will be required		Phase 3		
Timeframe(s)		From time-to-time during months 7 to 30		

5.3 Ore-processing Methods

There are numerous basic ore processing that are available to prospective miners, all of which could be modified and coupled to form multiple hybrid ore-processing methods.

5.3.1 Some Primary / Secondary Crushing

Jaw crusher

The working principle of jaw crushers is based on the reciprocating movement of the movable jaw with its maximum movement at the top of the crushing chamber and a minimum movement at the discharge point that compresses and crushes the ore between itself and the fixed jaw, as the material enters the zone between the jaws.

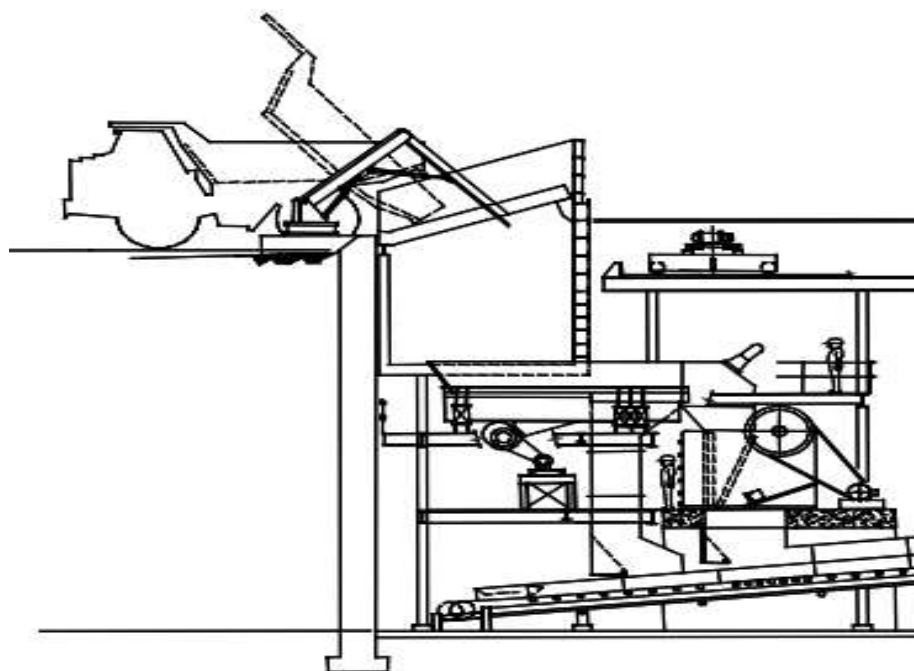

Figure 6: Section of a typical Jaw Crusher

Gyratory

Gyratory crushers work on a similar principle to jaw crushers but have a circular gap. Rock is compressed between a static conical bowl and a concave mantle which oscillates about the central axis.

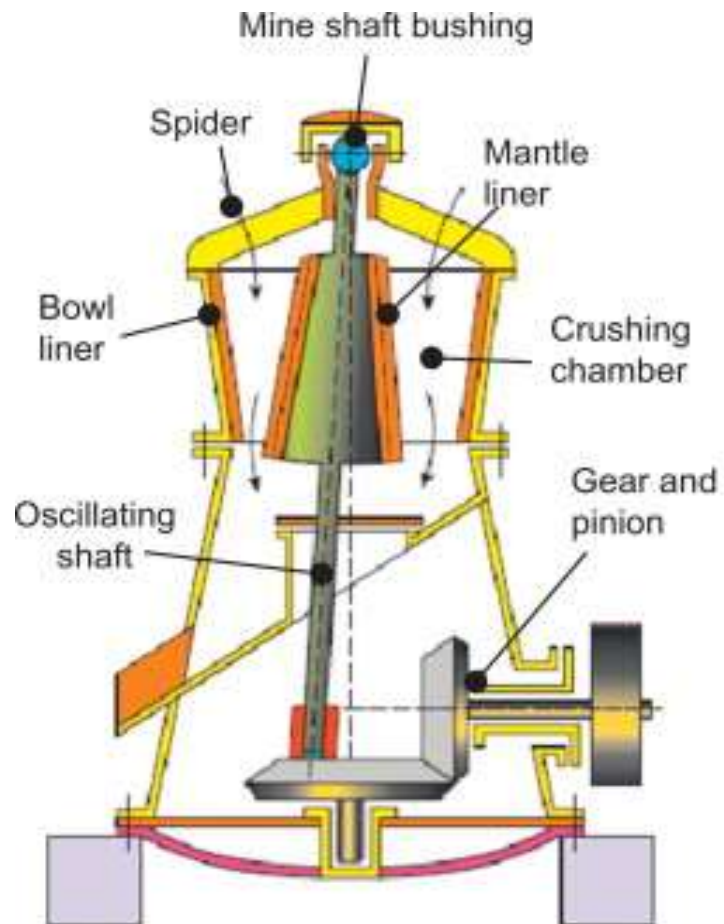

Figure 7: Schematic diagram of Gyratory Crusher

Cone Crusher

Cone crusher is a modified gyratory crusher. Cone crushers are used at secondary crushing stage for intermediate and fine crushing. Cone crushers are relatively more versatile than other crushers as they may be utilised at primary, secondary or tertiary crushing stage of the process.

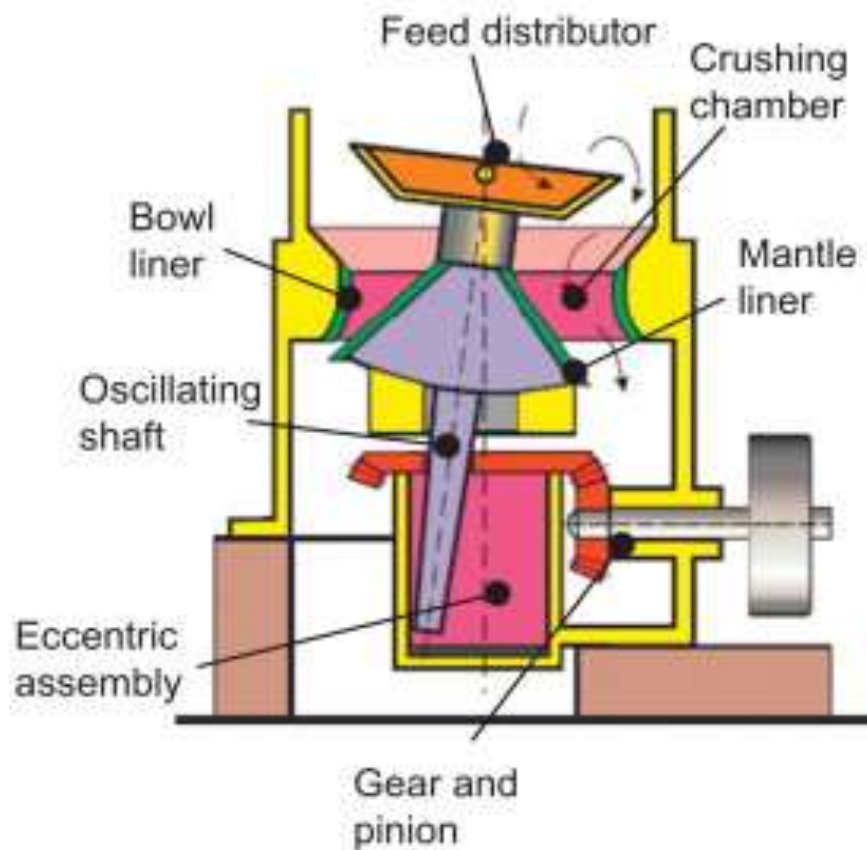

Figure 8: Schematic diagram of Cone Crusher

5.4 Some Process Plants

Dense Media Separation Plant is relatively more expensive to operate than Jig Plant. As the name suggests, DMS plant is more dependent on density as a parameter to control during operation. Efficient separation depends on bottom size, near density material, optimum yield and recovery, but can give lower tailings grades. Figure 7 shows a picture of Dense Medium Separation.



Figure 9: Dense Medium Separation

Jig Plant is relatively cheaper to operate than DMS Plant. The main parameters to monitor during operation are both size and density for improved efficiency. Jig plant yields relatively less efficient separation as a result of narrow size fractions, recovery losses, but can give higher tailings grade. Schematic diagram of Jig Plant is presented in Figure 10.

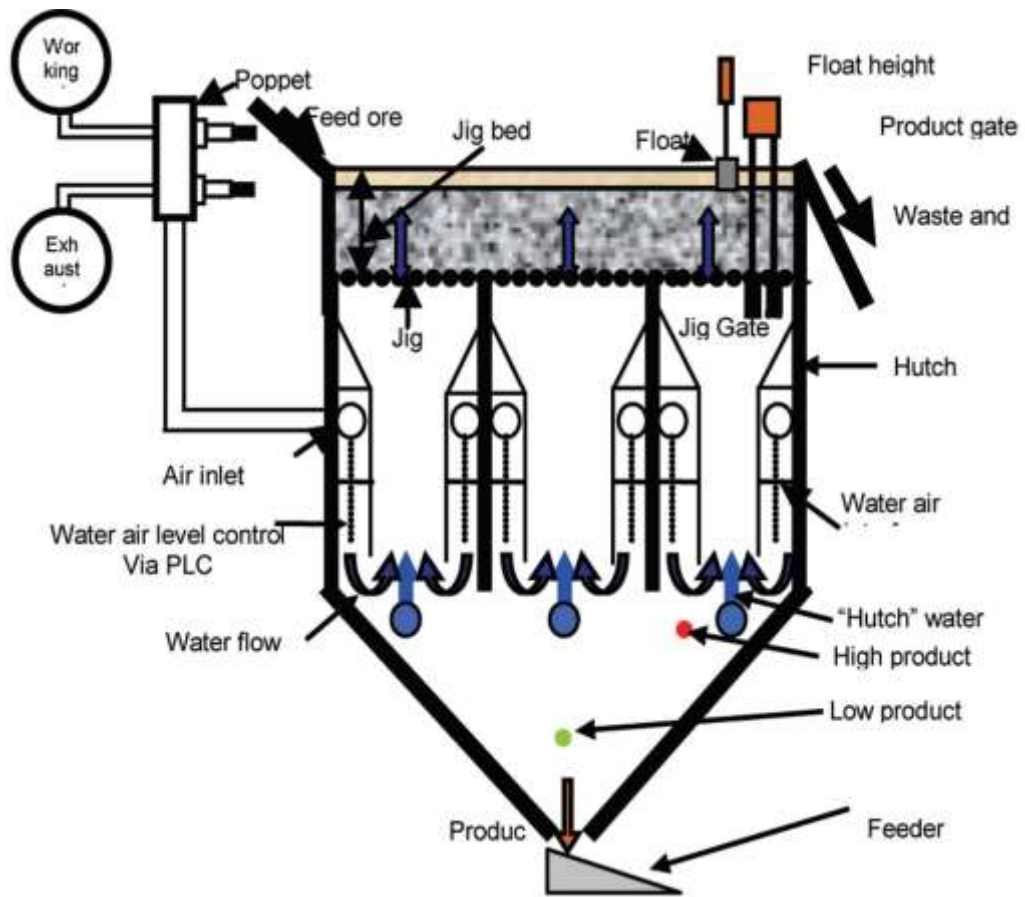

Figure 10: Schematic representation of Jig Plant

5.5 Beneficiation

Generally, ores are classified according to their size and the processing method as presented in Table 7.

Table 6: Classes of Ores

Class	Process Description	Diameter (mm)
Ore Lump	Are charged without further processing into a blast furnace or into a direct reduction furnace.	10 – 40
Ore Fine	Are agglomerated by a sintering plant before being charged into a blast furnace.	0.15 - 10
Pellet feed	Are agglomerated by a pelletizing plant before being charged into a blast furnace or into a direct reduction furnace.	<0.15
Concentrate	Concentrate is ore upgraded by a beneficiation process.	
Sintered ore	Sintered ore is ore agglomerated by a sintering plant.	
Pellet	Pellet is ore agglomerated by a pelletizing plant.	

Typical flow of sintering plant is presented in Figure 9 and typical flow of KOBELCO pelletizing system is presented in Figure 12.

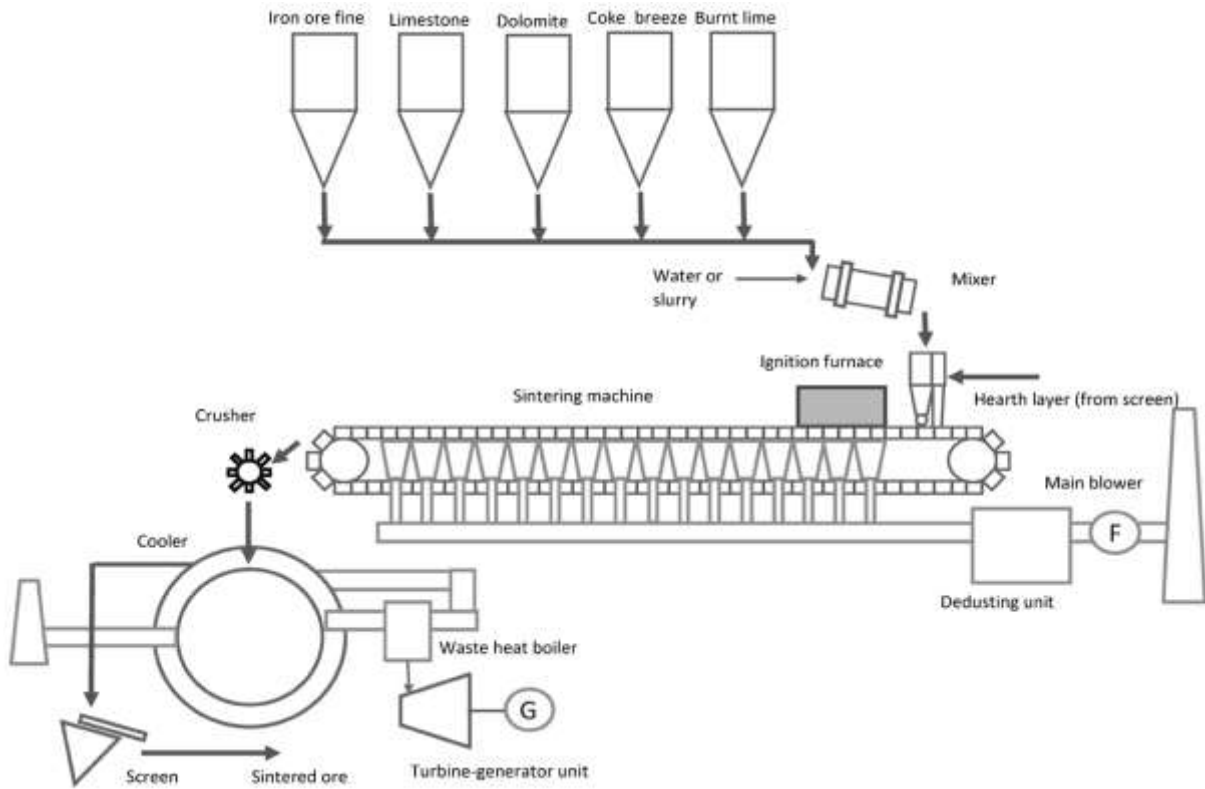

Figure 11: Schematic diagram of typical flow of sintering plant

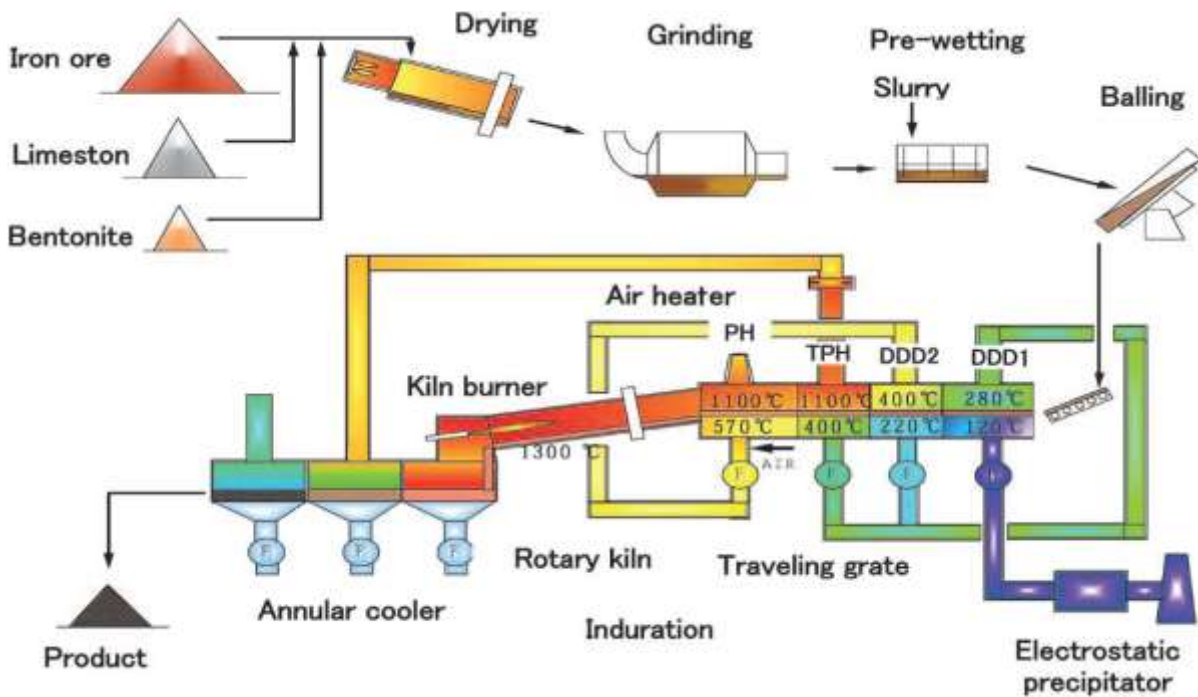

Figure 12: Typical flow diagram of KOBELCO pelletizing system.

6 Project Alternatives

In terms of the EIA Regulations (2017), Section 21(3) - Appendix 2 (h) a full description of the process followed to reach the proposed preferred activity, site and location of the development footprint within the site is required. In addition, the obligation that alternatives are investigated is also a required in terms of Section 24(7) of the National Environmental Management Act, 1998 (Act No. 107 of 1998)(NEMA) (as amended). An alternative in relation to a proposed activity refers to the different means of meeting the general purpose and requirements of the activity (as defined in Government Notice R326 of the EIA Regulations, 2017), which may include alternatives to:

- a) The property on which or location where it is proposed to undertake the activity.
- b) The type of activity to be undertaken.
- c) The design or layout of the activity.
- d) The technology to be used in the activity.
- e) The operational aspects of the activity.

Sections 24(4)(b)(i) and 24(4A) of the NEMA make provision for an EIA to encompass investigation and assessment of impacts that are associated with alternatives in relation to a proposed project. Furthermore, Section 24O(1)(b)(iv) provides for the Competent Authority, in its evaluation of Environmental Authorisation, takes into account “where appropriate, any feasible and reasonable alternatives to the activity which is the subject of the application and any feasible and reasonable modifications or changes to the activity that may minimise harm to the environment”.

It is common practise for assessment of alternatives to include the following:

- The consideration of the no-go alternative as a baseline scenario;
- A comparison of the reasonable and feasible alternatives; and
- Providing a methodology for the elimination of an alternative.

6.1 Site Alternatives

In order to determine a relatively suitable site / property for a proposed development, various factors should be considered. However, only the application area relevant to this piece of work was considered for application that was lodged with the DMRE. Alternative sites / properties are not applicable.

6.2 “No-go” Alternatives

The “No-go” alternative is, in essence, based on repercussions associated with the option of not going ahead with a proposed Project.

An opportunity to prospect for mineral resources in order to boost the economy, revenue collection by the State and contribution towards job creation will be lost if the proposed development plan does not become implemented.

6.2.1 Site Layout Alternatives

The site layout alternatives are going to be considered during the Environmental Impact Assessment that is going to be conducted. Alternative site layout alternatives are expected to be influenced significantly by the findings and recommendations of the detailed specialist studies that are going to be conducted during the second phase of this piece of work. In order to determine a relatively suitable site for the proposed development, various factors were considered. These factors include the following:

- Accessibility of location;
- Availability of infrastructure;
- Available Literature;
- The availability of ore body of economic value underground and water;
- Avoidance measures in terms of sterilising mineral resources; and
- General environmental and socio-economic justice that is possible to achieve pertaining to the proposed development.

6.3 Prospecting Activity Alternatives

Currently, the proposed site is the only one applied for in respect of this piece of work. Consideration is going to be made of the information as presented in section 2 to ensure relevant, effective and efficient alternatives are utilised.

A recommendation on the prospecting method of choice is going to be made at EIA phase pertaining to these proposed mineral resources development.

6.4 Some Technology Alternatives

Technology alternatives that are applicable to the proposed development are discussed in section 2.

6.5 Water Supply Infrastructure

A key aspect of the National Water Policy is Integrated Water Resources Management (IWRM). This recognises that water resources can only be successfully managed if the natural, social, economic and political environments in which water occurs and is used are taken into consideration. IWRM aims to strike a balance between the use of water resources for livelihoods and conservation of the resource whilst promoting social equity, environmental sustainability and economic growth and efficiency.

In a province such as the Northern Cape, more specifically in the John Taolo Gaetsewe District where surface water resource is scarce, the abstraction of water from groundwater resources becomes the preferred alternative. Comprehensive investigations pertaining to water supply are going to be conducted during the EIA phase.

6.6 Waste Storage, Management and Transportation

Waste is expected to be generated as a result of the proposed development and associated activities. It is proposed that waste that is generated on site should be separated at source. Waste Separation at Source pertains to setting aside post-consumer dry recyclable waste and household generated garden waste for the purpose of re-use, recycling, composting, or further processing of these materials.

Enormous value in waste separation at source emanates from, among others, procurement, recycling materials that are well sorted and uncontaminated. A basic requirement to achieve this value is that as much as possible, and efficiently as possible, waste or materials are separated early in the recycling process. This is separating waste at source essentially.

In South Africa, waste management is governed by the National Environmental Management: Waste Act, 2008 (Act No. 59 of 2008) which came into effect on 1 July 2009. Following the enactment of the NEM:WA, the Minister of Environmental Affairs established the National Waste Management Strategy (NWMS) to ensure the achievement the objectives of the NEM:WA. The NWMS was approved for implementation by the Cabinet in November 2011. The Waste Act supports the waste management hierarchy in its approach to waste management, by promoting cleaner production, waste minimisation, reuse, recycling and waste treatment with disposal seen as a last resort in the management of waste. There are a number of types of waste to be transported. Before any waste is transported, the person responsible for transporting such waste needs to assess the nature as well as the requirements for a specific load if waste to be transported. Understandably the preparations for transporting building rubble for instance, would be different to that of medical waste.

7 Legal Requirements

In order to protect the environment and ensure that this development is undertaken in an environmentally responsible manner, there are a number of significant pieces of legislation that will be consulted for this study. After a brief scoping of applicable legislation these include but may not be limited to the following:

7.1 The Constitution of the Republic of South Africa, 1996

The Constitution of the Republic of South Africa, 1996 is the supreme law and the nucleus of all legislation in South Africa. The Constitution guarantees equality before the law, all the basic freedoms which human beings must enjoy, and must be reasonably entitled to, social and economic justice.

Section 24 of the Constitution states that:

“Everyone has the right:

- *to an environment that is not harmful to their health or well-being; and*
- *to have the environment protected, for the benefit of present and future generations through reasonable legislative and other measures that –*
 - *prevent pollution and ecological degradation;*
 - *promote conservation; and*
 - *secure ecologically sustainable development and use of natural resources while promoting justifiable economic and social development.”*

Section 24 of the Constitution therefore guarantees citizens of South Africa the right to an environment that is not harmful to human health or well-being, and specifically imposes a duty on the State to enact legislation and take necessary steps to ensure that the right is upheld and to ensure sustainable development through prevention, minimization of control of ecological degradation and pollution. As enshrined in the Bill of Rights, the environmental management objectives of proposed project is to ensure that present and future generations benefit from this development, to support sustainable development and the use of natural resources, whilst promoting justifiable socio-economic development in nearby communities to the project location.

7.2 NEMA and EIA Regulations published on 7 April 2017 (GN R327, GN R326, GN R325 and GN R324)

The National Environmental Management Act, 1998 (Act No. 107 of 1998) sets out a number of principles in the first two (2) chapters of the act to give guidance to applicant or proponents, private land owners, members of public and authorities on how to handle environmental matters. The NEMA is the national legal framework that regulates environmental issues. Various necessities such as cooperative environmental governance, compliance and non-compliance, enforcement, and regulating government and business impacts on the environment, underpin the NEMA. The NEMA, as the primary environmental legislation, is complemented by a number of sectoral laws governing mining, waste, air quality, biodiversity, marine living resources, forestry, protected areas, pollution and integrated coastal management. The triple bottom line principle proposes that development must be socially, environmentally and economically sustainable. Principle Number 4(a) states that all relevant factors must be considered, inter alia i) that the disturbance of ecosystems and loss of biological diversity are avoided, or, where they cannot be altogether avoided, are minimised and remedied; ii) that pollution and degradation of the environment are avoided, or, where they cannot be altogether avoided, are minimised and remedied; vi) that the development, use and exploitation of renewable resources and the ecosystems of which they are part do not exceed the level beyond which their integrity is jeopardised; and viii) that negative impacts on the environment and on peoples' environmental rights be anticipated and prevented, and where they cannot be altogether prevented, are minimised and remedied.

The national legal framework under which Environmental Impact assessments are undertaken is the National Environmental Management Act, 1998 (Act No. 107 of 1998) NEMA (as amended). The EIA studies under discussion are often complex as a result of many contributing factors. For purposes of remaining within the scope of work of this study, it is not necessary to discuss further these complexities. It is therefore important to highlight that the ultimate aim of EIA studies is to uphold environmental and

socio-economic justice pertaining to any proposed development among other things. A definition of “environment” is given in section 1 of the NEMA. Section 2(2) of the NEMA urges sensitivity to the welfare of communities regarding their physical psychological, developmental, cultural and social interests. Development must be socially, environmentally and economically sustainable, which requires that the disturbance of landscapes and sites that constitute the nation’s cultural heritage is avoided, or where it cannot be altogether avoided, is minimized and remedied.

The EIA Regulations (2017) under the NEMA consist of three (3) categories of activities namely: Listing Notice 1 Activities (GNR. 327 of 2017) which require a Basic Assessment study, Listing Notice 2 Activities (GNR. 325 of 2017) which require both a Scoping and an EIA study for authorisation and Listing Notice 3 Activities (GNR. 324 of 2017) which requires a Basic Assessment study for specific activities in identified sensitive geographical areas. The DMRE is responsible for the authorisation of these activities.

7.3 The National Heritage Resources Act, 1999 (Act No. 25 of 1999)

The National Heritage Resources Act, 1999 (Act No. 25 of 1999) provides legal framework for the management of cultural and heritage resources in South Africa. Section 3 of the NHRA lists a wide range of phenomena under which resources may fall with the definition of heritage.

The NHRA was promulgated in order to introduce an integrated and interactive system for the management of the heritage resources, to promote good government at all levels, and empower civil society to nurture and conserve heritage resources so that they may be bequeathed to future generations and to lay down principles for governing heritage resources management throughout the Republic.

In terms of section 38 (subject to the provisions of subsections (7), (8) and (9) of the Act), any proponent who proposes to undertake a development categorised as:

- The construction of a road, wall, power line, pipeline, canal or other similar form of linear development or barrier exceeding 300 m in length;
- The construction of a bridge or similar structure exceeding 50 m in length;
- Any development or other activity which will change the character of a site: - Exceeding 5 000 m² in extent;
 - Involving three or more existing erven or subdivisions thereof; or
 - Involving three or more erven or divisions thereof which have been consolidated within the past five years; or

- The costs of which will exceed a sum set in terms of regulations by SAHRA or a provincial heritage resources authority;
- The re-zoning of a site exceeding 10 000 m² in extent; or
- Any other category of development provided for in regulations by SAHRA or a provincial heritage resources authority, must at the very earliest stages of initiating such a development, notify the responsible heritage resources authority and furnish it with details regarding the location, nature and extent of the proposed development.

The provincial/national offices of the South African Heritage Resource Agency (SAHRA) are going to be provided with all relevant documentation that will enable them to make an informed statutory comment as enshrined in the NHRA.

A Heritage Impact Assessment and a Palaeontological Impact Assessment (Desktop Study) are going to be undertaken during the EIA Phase of the proposed Project. These environmental specialist studies will be included in the EIA Reports that is going to be published for review by I&APs during the EIA Phase.

In order to comply with the South African Heritage Resources Agency (SAHRA) in terms of Section 38(8) of the National Heritage Resources Act, 1999 (Act No. 25 of 1999) (NHRA), a desktop Palaeontological Impact Assessment (PIA) is going to be completed for the proposed applications and findings and recommendations of specialist are going to be considered in the EIA.

7.4 The National Water Act, 1998 (Act No. 36 of 1998)

The National Water Act, 1998 (Act No. 36 of 1998) (NWA) makes provision for Section 21 Water Uses for which an application could be lodged and those that already exist. The NWA is the principal legal instrument relating to water resource management in South Africa and contains comprehensive provisions for the protection, use, development, conservation, management and control of the country's water resources. In addition, the management of water as a renewable resource must be carried out within the framework of environmental legislation, i.e. the National Environmental Management Act, 1998 (Act No. 107 of 1998) (NEMA), under Regulations R324 to 327, of 07 April 2017.

A key aspect of the National Water Policy is Integrated Water Resources Management (IWRM). This recognises that water resources can only be successfully managed if the natural, social, economic and political environments in which water occurs and is used are taken into consideration. IWRM aims to strike

a balance between the use of water resources for livelihoods and conservation of the resource whilst promoting social equity, environmental sustainability and economic growth and efficiency.

In addition to the National Water Act, 1998 (Act No. 36 of 1998) and the National Environmental Management Act, 1998 (Act No. 107 of 1998), the following legislation and guidelines/quality standards are applicable to hydrogeological investigations and assessments:

- National Water Act, 1998 (Act No. 36 of 1998);
- National Water Resource Strategy (NWRS, 1st Ed., September 2004);
- Department of Environmental Affairs and Development Planning's (DEA&DP) Guideline for Involving Hydrogeologists in EIA Processes (June 2005) (Snayman, 2005);
- Department of Water Affairs and Forestry's (DWAF) Integrated Water Resource Management: Guidelines for Groundwater Management in Water Management Areas in South Africa (DWAF, 2004).

The NWA defines eleven (11) consumptive and non-consumptive water uses:

- 21(a): Taking water from a water resource;
- 21(b): Storing water;
- 21(c): Impeding or diverting the flow of water in a watercourse;
- 21(d): Engaging in a stream flow reduction activity;
- 21(e): Engaging in a controlled activity;
- 21(f): Discharging waste or water containing waste into a water resource through a pipe, canal, sewer or other conduit;
- 21(g): Disposing of waste in a manner which may detrimentally impact on a water resource;
- 21(h): Disposing in any manner of water which contains waste from, or which has been heated in any industrial or power generation process;
- 21(i): Altering the bed, banks, course or characteristics of a watercourse;
- 21(j): Removing, discharging or disposing of water found underground if it is necessary for the efficient continuation of an activity or for the safety of people; and,
- 21(k): Using water for recreational purposes.

Section 27 of the NWA specifies that the following factors regarding water use authorisation be taken into consideration:

- The efficient and beneficial use of water in the public interest;
- The socio-economic impact of the decision whether or not to issue a license;
- Alignment with the catchment management strategy;
- The impact of the water use and possible resource directed measures; and,
- Investments made by the Applicant in respect of the water use in question.

This EIA study underway is going to be used to support the Water Use Licencing Application Process.

7.4.1 Controlled Activities

The Minister of Human Settlements, Water and Sanitation is allowed to regulate activities which have a detrimental impact on water resources by declaring them to be controlled activities. The following are considered to be controlled activities:

- Irrigation of any land with waste or water containing waste generated through any industrial activity or by a water work;
- An activity aimed at the modification of atmospheric precipitation;
- A power generation activity which alters the flow regime or a water resource;
- Intentional recharging of an aquifer with any waste or water containing waste; and
- An activity which has been declared as such under Section 38.

No person may undertake a controlled activity unless such person is authorised to do so by or under this Act. The Minister may, by notice in the Gazette, in general or specifically, declare an activity to be a controlled activity. Such notice might be for a specific activity on a specific site.

7.5 National Environmental Management: Waste Act, 2008 (Act No. 59 of 2008)

The National Environmental Management Waste Act, 2008 (Act No. 59 of 2008) has been developed as part of the law reform process enacted through the White Paper on Integrated Pollution and Waste Management and the National Waste Management Strategy (NWMS).

The objectives of the NEM:WA relate to the provision of measures to protect health, well-being and the environment, to ensure that people are aware of the impact of waste on their health, well-being and the environment, to provide for compliance with the measures, and to give effect to section 24 of the Constitution in order to secure an environment that is not harmful to health and well-being.

Government Notice Regulations 921 (of 29 November 2013) promulgated in terms of Section 19(1) of the National Environmental Management: Waste Act, 2008 (Act No. 59 of 2008) determine that no person may commence, undertake or conduct a waste management activity listed in the schedule unless a license is issued in respect of that activity.

7.6 Agricultural Laws Rationalisation Act, 1998 (Act No. 72 of 1998)

The Agricultural Laws Rationalisation Act, 1998 (Act No. 72 of 1998) was enacted in order to provide for the rationalisation of certain laws relating to agricultural affairs that remained in force in various areas of the national territory of the Republic prior to the commencement of the Constitution of the Republic of South Africa; and to provide for matters connected therewith.

The agricultural laws that were promulgated after the enactment of the Agricultural Laws Rationalisation Act have to be consistent with the provisions of the Constitution.

7.7 National Environmental Management: Air Quality Act, 2004 (Act No. 39 of 2004)

The object of the National Environmental Management: Air Quality Act, 2004 (Act No. 39 of 2004) is to protect the environment by providing reasonable measures for the protection and enhancement of the quality of air in South Africa; the prevention of air pollution and ecological degradation; and securing ecologically sustainable development while promoting justifiable economic and social development.

Government Notice Regulation 248 (of 31 March 2010) promulgated in terms of Section 21(1)(a) of the National Environmental Management Act: Air Quality Act (Act No. 39 of 2004) determine that an Atmospheric Emission License (AEL) is required for certain listed activities, which result in atmospheric emissions which have or may have a detrimental effect on the environment. The Regulation also sets out the minimum emission standards for the listed activities. It is not envisaged that an Atmospheric Emission License will be required for the proposed development.

7.8 National Environmental Management: Biodiversity Act, 2004 (Act No. 10 of 2004)

The National Environmental Management: Biodiversity Act, 2004 (Act No. 10 of 2004) (NEM:BA) provides for “the management and conservation of South Africa’s biodiversity within the framework of the NEMA, the protection of species and ecosystems that warrant national protection, and the use of indigenous

biological resources in a sustainable manner, amongst other provisions". The NEM:BA specifies that the state is the custodian of South Africa's biological diversity and is committed to respect, protect, promote and fulfil the constitutional rights of its citizens.

Furthermore, the NEM:BA prohibits loss of biodiversity through habitat loss, degradation or fragmentation must be avoided, minimised or remedied. The loss of biodiversity includes inter alia the loss of threatened or protected species. Biodiversity offsets are a means of compensating for the loss of biodiversity after all measures to avoid, reduce or remedy biodiversity loss have been taken, but residual impacts still remain and these are predicted to be medium to high. Chapter 5 of NEM:BA (Sections 73 to 75) regulates activities involving invasive species, and lists duty of care as follows:

- the land owner/land user must take steps to control and eradicate the invasive species and prevent their spread, which includes targeting offspring, propagating material and regrowth, in order to prevent the production of offspring, formation of seed, regeneration or re-establishment;
- take all required steps to prevent or minimise harm to biodiversity; and
- ensure that actions taken to control/eradicate invasive species must be executed with caution and in a manner that may cause the least possible harm to biodiversity and damage to the environment.

An amendment to the NEM:BA has been promulgated, which lists 225 threatened ecosystems based on vegetation types present within these ecosystems. Should a project fall within a vegetation type or ecosystem that is listed, actions in terms of NEM:BA are triggered.

7.9 National Forests Act, 1998 (Act No. 84 of 1998)

The National Forest Act, 1998 (Act No. 84 of 1998) allows for the protection of certain tree species. The Minister has the power to declare a particular tree to be a protected tree. According to Section 12 (1) d (read with Sections (5) 1 and 62 (2) (c)) of the National Forest Act (Act 84 of 1998), a licence is required to remove, cut, disturb, damage or destroy any of the listed protected trees. The most recent list of protected tree species was published in November 2014. The Department of Agriculture, Forestry and Fisheries (DAFF) is authorised to issue licences for any removal, cutting, disturbance, damage to or destruction of any protected trees. The protected trees that commonly occur in this region are *Acacia erioloba* and *Boscia albitrunca*.

7.10 Conservation of Agricultural Resources Act, 1983 (Act No. 43 of 1983)

The objectives of the Conservation of Agricultural Resources Act, 1983 (Act No. 43 of 1983) (CARA) are to provide for the conservation of the natural agricultural resources of South Africa by the:

- maintenance of the production potential of land;
- combating and prevention of erosion and weakening or destruction of the water sources; and
- protection of the vegetation and the combating of weeds and invader plants.

The CARA states that no land user shall utilise the vegetation of wetlands (a watercourse or pans) in a manner that will cause its deterioration or damage. This includes cultivation, overgrazing, diverting water run-off and other developments that damage the water resource. The CARA includes regulations on alien invasive plants. According to the amended regulations (GN R280 of March 2001), declared weeds and invader plants are divided into three categories:

- Category 1 may not be grown and must be eradicated and controlled;
- Category 2 may only be grown in an area demarcated for commercial cultivation purposes and for which a permit has been issued, and must be controlled; and
- Category 3 plants may no longer be planted and existing plants may remain as long as their spread is prevented, except within the flood line of watercourses and wetlands. It is the legal duty of the land user or land owner to control invasive alien plants occurring on the land under their control.

Should alien plant species occur within the study area; this will be managed in line with the EMP. Rehabilitation after disturbance to agricultural land is also managed by CARA. The DAFF reviews and approves applications in terms of these Acts according to their Guidelines for the evaluation and review of applications pertaining to renewable energy on agricultural land, dated September 2011.

7.11 Subdivision of Agricultural Land Act, 1970 (Act No. 70 of 1970)

A change of land use (re-zoning) for the development on agricultural land needs to be approved in terms of the Subdivision of Agricultural Land Act, 1970 (Act No. 70 of 1970) (SALA). This is required for long term lease, even if no subdivision is required.

7.12 Development Facilitation Act, 1995 (Act No. 67 of 1995)

The Development Facilitation Act, 1995 (Act No. 67 of 1995) (DFA) sets out a number of key planning principles which have a bearing on assessing proposed developments in light of the national planning requirements. The planning principles most applicable to the study area include:

- Promoting the integration of the social, economic, institutional and physical aspects of land development;
- Promoting integrated land development in rural and urban areas in support of each other;
- Promoting the availability of residential and employment opportunities in close proximity to or integrated with each other;
- Optimising the use of existing resources including such resources relating to agriculture, land, minerals, bulk infrastructure, roads, transportation and social facilities;
- Contributing to the correction of the historically distorted spatial patterns of settlement in the Republic and to the optimum use of existing infrastructure in excess of current needs;
- Promoting the establishment of viable communities; and
- Promoting sustained protection of the environment.

7.13 Spatial Planning and Land Use Management Act, 2013 (Act No. 16 of 2013)

The Spatial Planning and Land Use Management Act, 2013 (Act No. 16 of 2013) was promulgated in order to enhance planning and land use management efficiently and effectively. The SPLUMA enable urban areas to drive spatial transformation.

7.14 Other Relevant Pieces of Legislation

- Mineral and Petroleum Resources Development Act, 2002 (Act No. 28 of 2002);
- National Environmental Management: Protected Areas Act, 2003 (Act No. 57 of 2003);
- Agricultural Laws Rationalisation Act, 1998 (Act No. 72 of 1998);
- Conservation of Agricultural Resources Act, 1983 (Act No. 43 of 1983);
- National Heritage Resources Act, 1999 (Act No. 25 of 1999);
- Fencing Act, 1963 (Act No. 31 of 1963);
- Electricity Act, 1987 (Act No. 41 of 1987);

- Electricity Regulations Amendments (August 2009);
- Biodiversity Act, 2004 (Act No. 10 of 2004);
- Hazardous Substance Act, 1973 (Act No. 15 of 1973);
- Agricultural Product Standards Act, 1993 (Act No. 129 of 1993);
- Occupational Health and Safety Act, 1993 (Act No. 85 of 1993) and Regulations;
- Mine Health and Safety Act, 1996 (Act No. 29 of 1996);
- Road Transportation Act, 1977 (Act No. 74 of 1977);
- Civil Aviation Authority Act, 1998 (Act No. 40 of 1998); and
- Civil Aviation Act, 2009 (Act No. 13 of 2009) and Civil Aviation Regulations (CAR) of 1997;

7.14.1 Provincial Legislation

i. Northern Cape Nature Conservation, 2009 (Act No. 09 of 2009)

The Northern Cape Nature Conservation Act, 2009 (Act No. 09 of 2009) and in particular the Northern Cape Conservation promotes the protection of listed species. The Northern Cape Nature Conservation Act provides for sustainable development in terms of establishing and maintaining balance in the use of natural resource and protection or conservation thereof. The Act includes six schedules, as follows:

- Schedule 1 - Specially Protected species;
- Schedule 2 - Protected species;
- Schedule 3 - Common indigenous species;
- Schedule 4 - Damage causing animal species;
- Schedule 5 - Pet species; and
- Schedule 6 - Invasive Species.

With regards to protected flora, the Northern Cape Nature Conservation Act includes a list of protected flora. The plant species potentially present within the proposed project area should be identified as part of the Biodiversity Assessment. However, it will be recommended as part of the EMP, that a detailed plant search and rescue operation be conducted before the final design process and prior to the commencement of surface disturbances, if applicable. If any of the listed species are found, the relevant permits should be obtained by the proponent prior to their relocation or removal. In addition, the Northern Cape Department of Agriculture, Environmental Affairs, Rural Development and Land Reform must be consulted before the planned clearance of indigenous vegetation on site takes place.

ii. **The Provincial Spatial Development Framework for the Northern Cape (Office of the Premier of the Northern Cape, 2012)**

The Provincial Spatial Development Framework (PSDF) provides for developmental planning to in consistence with the provincial legislation. In the province of the Northern Cape where agriculture and mining are predominant, solar and wind renewable energy are now emerging as some of the province's major activities.

The spatial vision for the province outlines a well-structured system of sustainable land-use zones that support the Northern Cape's economy vested in the primary economic sectors, in particular, mining, agriculture, tourism, and the energy industry.

8 Public Participation Process

An application was lodged with the Department of Mineral Resources and Energy. Another pre-application consultation meeting is going to be conducted with the Department of Human Settlements, Water and Sanitation, Kimberley, Northern Cape. The Public Participation Process pertaining to Integrated Environmental Authorisation and Integrated Water Use License Applications were conducted jointly.

Interested and Affected Parties (I&AP's) are going to be notified of the proposed Project Application via e-mails, notices in public spaces, newspaper adverts or facsimiles and / or virtual conferencing platforms. Site notices are going to be placed around the application area. In addition, newspaper advertisements (in English) will be placed in a newspaper which is widely distributed in the area. The Public Participation Process will be undertaken in accordance with the NWA and the NEMA process and the 2017 EIA Regulations (as amended). I&AP's will be provided an initial notification and call to register period of 30 days. The draft Scoping and Environmental Impact Assessment Report was made available for public review and comment for a minimum period of 30 days each. During this period, an Open Day will be scheduled to present the findings of the draft Environmental Impact Assessment Report to the public. All correspondence submitted by I&AP's will be utilised during the impact assessment and all correspondence received from I&AP's will be included in the final Environmental Impact Assessment Report.

The Environmental Impact Assessment Report and Environmental Management Programme (EMPr) for comment will be made available to all Registered Interested and Affected Parties (I&AP's). In order to

take part in the process and to submit comments on these documents, I&AP's are invited to register by completing the registration form and sending it back to the consultant.

Information on the environment, the impacts of the proposed Project and recommended mitigation and management measures; as well as more information on the application itself, will be described in these documents.

The public participation process will be conducted strictly in accordance with applicable regulations. The following categories of variables will take into account when deciding the required level of public participation:

- The scale of anticipated impact; and
- The sensitivity of the affected environment.

Consultation is required in terms of Chapter 6 of the EIA Regulations, 2017. Landowners, neighbours and other Interested and Affected Parties (I&AP's) are entitled to participate in and be consulted in respect of new proposed agricultural development applications. The proposed PPP for this application will include a number of steps, as listed below:

- Newspaper advertisement in local newspaper;
- Site notices;
- Notification of surrounding land owners, land occupiers and current right owners around;
- Specialist studies will be conducted including the use of available environmental reports; and
- Public Meeting with stakeholders involved e.g., community.

8.1 Overview of the Public Participation Process Undertaken during the Scoping Phase

The primary aims and objectives of conducting public participation process during the Scoping Study are as follows:

- To notify Interested and Affected Parties (I&APs) of the proposed Project;
- To document and consider issues, comments and concerns as raised by I&APs;
- To promote transparency, increase participation and raise awareness on the proposed development and associated consequences;
- To provide platform for liaison and communication with I&APs; and

- To identify potential environmental, socio-economic impacts associated with the proposed development.

8.2 Availing of Background Information

Copies of Scoping Report were made accessible for review at the Kathu Library and / or Gamagara Local Municipality Offices and those of Environmental Impact Assessment Report will be made available for review in the same manner.

A briefing paper for the project has been compiled in English. The aim of this document is to provide a brief outline of the proposed project, provide preliminary details regarding the EIA Process, and explain how I&APs could become involved in the project. The briefing paper, together with a comment sheet and relevant map, was distributed to identified stakeholders and I&APs via e-mail, inviting them to register for participation the proposed development and submit details of any issues and concerns that they may have.

Furthermore, the briefing paper informed I&APs and Stakeholders of the prospective registration of the Project and invited to comment on the project throughout the process. An introductory letter was sent to all I&APs and Stakeholders together with the briefing paper, questionnaire and comments sheet.

8.3 Identification of Key Stakeholders

The first step in the Public Participation Process (PPP) is to identify key stakeholders, including:

- National and Provincial Government Representatives:
 - Department of Agriculture, Environmental Affairs, Rural Development and Land Reform (DAEARDLR);
 - Department of Human Settlement, Water & Sanitation (DHSWS);
 - Department of Public Enterprises;
 - Department of Trade and Industry (DTI);
 - Department of Mineral Resources and Energy (DMRE);
 - National Environmental Standards and Regulations Enforcement Agency (NESRA); and
 - South African Heritage Resources Agency (SAHRA).
- Relevant Local and District Municipalities;

- John Taolo Gaetsewe District Municipality;
- Gamagara Local Municipality;
- Tsantsabane Local Municipality; and
- Kgatelopele Local Municipality.
- State-owned Entities:
 - Transnet;
 - SANDF;
 - SACAA;
 - SANRAL; and
 - Eskom.
- Landowner and neighbours.

All I&AP information, together with record of dates and details of consultations and a record of all issues raised is recorded within a comprehensive project database. This database will be updated on an on-going basis throughout the project, and will act as a record of the communication/public involvement process.

8.4 Advertising

In compliance with the EIA Regulations (2017), notification of the commencement of the SR process for the project was advertised in a local newspaper, the project was advertised in the Kathu Gazette local newspaper in July 2023 in English. Only an advertisement in the Kathu Gazette newspaper was required as only the Kuruman town will be located within the Kathu Gazette distribution area.

The advertisement provided an abstract on key aspects of the Project (project description, location and contact details of the Environmental Assessment Practitioner). Furthermore, the advertisement requested I&APs to register, and to become involved in the project by submitting comments and highlighting issues of concern to Thaya Trading Enterprise. The primary aim of the newspaper advert is to ensure that the widest possible group of I&APs were informed of the project.

8.5 Site Notices

Site notices are going to be prepared according to the specifications set out in the EIA Regulations. The site notices included basic information regarding the proposed Project, the details of the public

participation period, the listed activities applicable to the project and the contact details of the Environmental Assessment Practitioner. Site notices were placed at public venues.

- Main Entrance gate of the Farm Gamohaan No. 438, near Kuruman, John Taolo Gaetsewe District, Northern Cape, South Africa;
- At Joe Morolong Local Municipality Notice Board;

8.6 Review of Environmental Scoping Report

8.6.1 Sharing of Draft Scoping Report with Interested and Affected Parties who requested for a copy

A database of records of all communication between I&APs and Thaya Trading Enterprise CC pertaining to the proposed development was created and managed.

8.6.2 Authority Review of Draft Environmental Scoping Report

The Consultation Environmental Scoping Report was made available for review and comments for a period of 43-days, to the following authorities:

- Department of Mineral Resources and Energy;
- Department of Human Settlement, Water and Sanitation; and

8.6.3 Public Review of Draft Environmental Scoping Report

The draft Environmental Scoping Report was made available for public review at the following public locations in close proximity to the study areas, which were identified as readily accessible to I&APs:

- Kathu Library;
- Hotazel Library;
- Batlharos Library;
- MS Kitchin Library;
- Tsineng Library.

The availability of this draft report is going to be advertised in the Kathu Gazette newspaper. A 30-day period is going to be allowed for this review process from July 2023 to August 2023 Stakeholders and I&APs on the project database are going to be notified of the availability of this report by letter (e-mail) as sent out in July 2023.

8.6.4 Final Environmental Scoping Report

The compilation of the Consultation Environmental Scoping Report entails the consideration and inclusion of all relevant comments received from the public during the review of the draft Scoping Report. The final document will be submitted to Department of Mineral Resources and Energy for authority review and decision-making and/or comments.

9 General or Baseline Description of the Study Area

The purpose of this section is to provide baseline description of the area of application. The John Taolo Gaetsewe District dominated by both agricultural and mining activities. It is a semi-arid area with relatively high radiation in the Northern Cape, South Africa.

9.1 Socio-economic, Biophysical Environment

9.1.1 Locality

The proposed Project is located (Figure 13) within an area whose zoning has not been requested for at the moment. The area of application is does not within a protected area and is therefore relatively less threatened. The findings of the proposed Biodiversity Assessment, if any, to be conducted will provide guidance of what trees are protected within the application area.

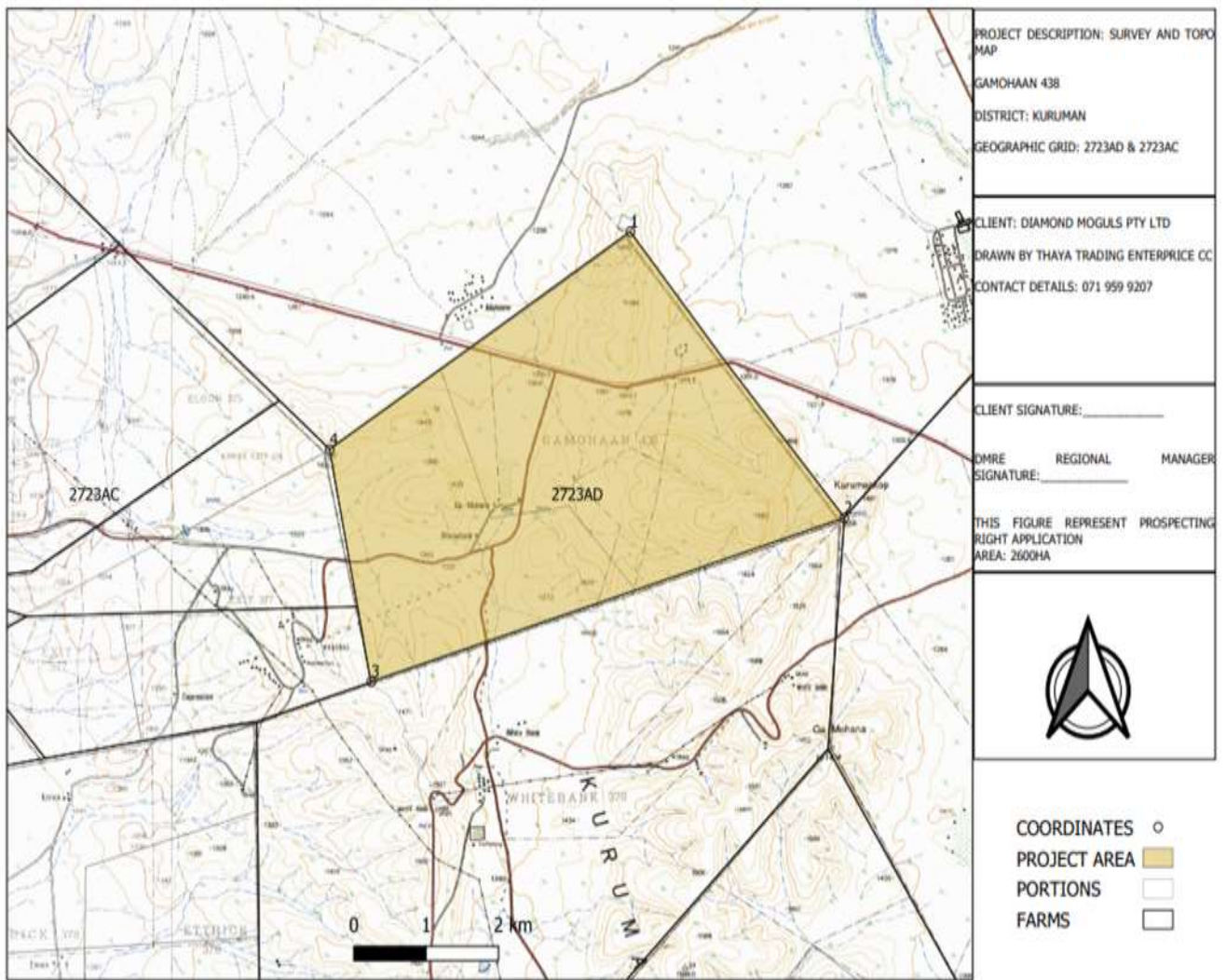

Figure 13: Project Application Area

Locality of the proposed development is depicted in Figure 14.

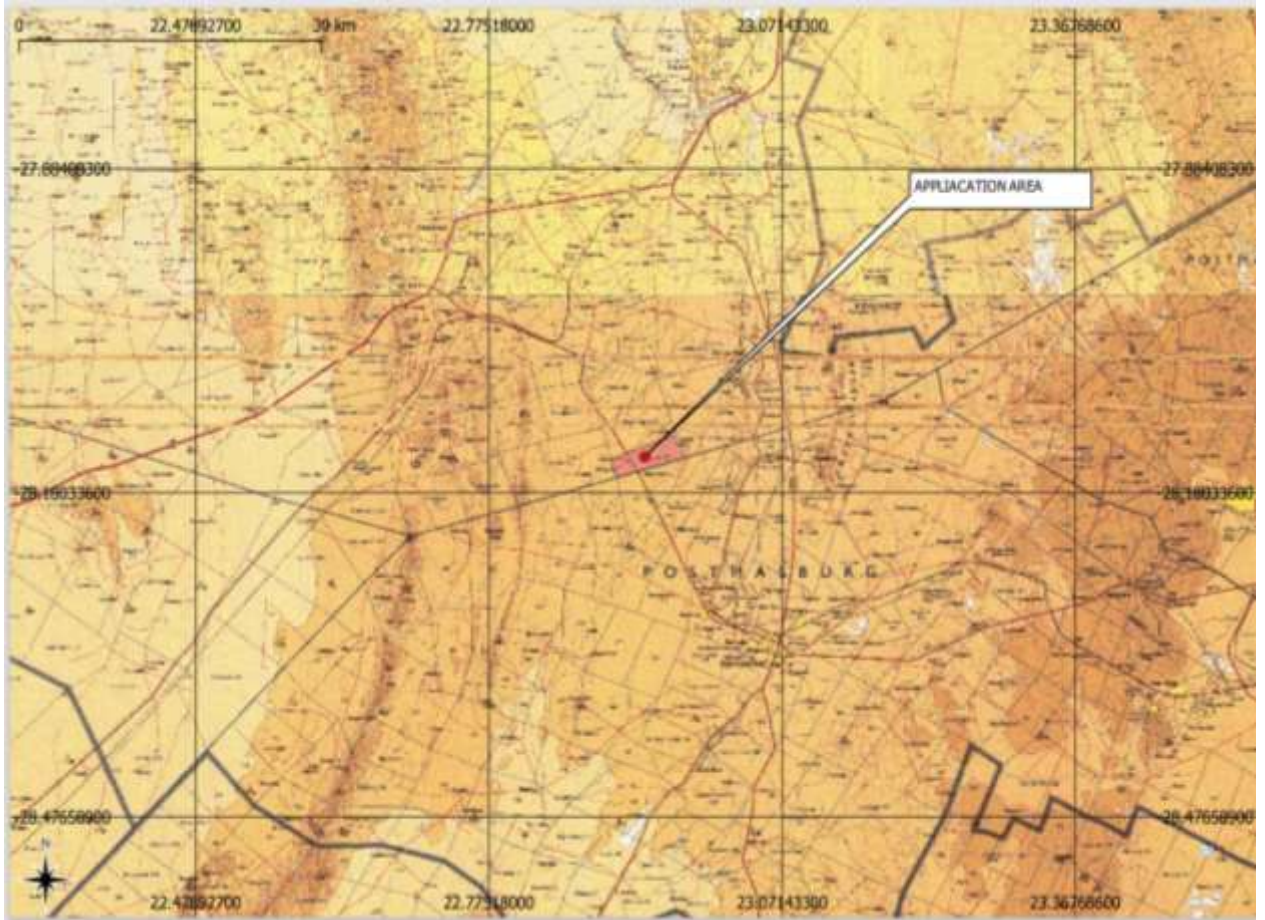

Figure 14: Locality Map of John Taolo Gaetsewe District

9.1.2 Geology

Rocks of the area are composed of pink white and grey fined-grained porphyritic granitic types which are the oldest rocks of the Swazian Erathem in the area.

The Schmidtsdrif Subgroup forms the lower part of the Ghaap Group and is divided into two formations (Boomplaas and Clearwater Formations) of approximately 100 m thick. In the middle of the formation shale becomes more predominant and ferruginised shale grey with siltstone and interbanded thin dolomite. Chert and chert conglomerate are present at the base. The upper formation consists of calcretic dolomite with few stromatolites and thin banded shale and siltstones (Beukes, 1987). The Ghaap Plateau Formation can be distinguished from the underlying formation only where the Iron and Manganese is present on the latter. Elsewhere the rocks consist of dark blue finegrained dolomite. A few stromatolite-bearing zones, small lenses of black chert locally developed in thin shale and siltstone are present. Brown ferruginous jasper layers up to 12 m thick, separate the lower part of the formation from the overlying grey coursegrained dolomite. A Breccia of black chert and a few stromatolites occur in the dolomite.

A third zone can be distinguished in the upper part of the formation. It contains lenses of limestone and a prominent layer of chert forms the top of the succession. The layer of chert occurs sporadically on the Maremane anticline where it is brecciated in places to form the silica breccia (Moen et al., 1977). Asbestos Hills Subgroup is the sole representative of the Ghaap Group in this area and follows conformably on the underlying rocks. The formation is divided into the Kuruman and Danielskuil Formations. The uppermost chert of the Ghaap Group grades into banded iron formation of the Kuruman Formation which varies in thickness from 180 m to 240 m. It consists of a succession of thin alternating layers of light-coloured chert and jasper and dark coloured ferruginous jaspilite. The jaspilite contains mainly magnetite, haematite and limonite. A few thin layers of riebeckite-amphibolite and shale occur in places. The rock has well developed bedding plane cleavage and contains several crocidolite bearing zones. The basal layer of the banded iron formation lies on the dolomite of the Ghaap Plateau Formation in the Maremane anticline, is brecciated and ferruginised in places and constitutes the Blinkklip Breccia (Moen et al., 1977).

The "Main Marker" with a thickness of approximately 10m, lies conformably on the banded iron formation (BIF) and forms the base of the overlying jaspilite. It is characterized by an undulating structure and consists of brown jaspilite with thin magnetite layer and chert nodules. The overlying jaspilite attains a thickness of 150 m and contains several marker layers. Several "speckled markers" are present in the lower 40 m of the succession, of which only the upper one is indicated on the map. In the south a layer of eolithic chert with the appearance of Iron and Manganese is associated with the upper speckled marker. The two together are known as the Iron and Manganese marker. The intermediate Iron and Manganese maker occurs between lower speckled markers (Moen, 1977). The Gamagara Formation was deposited on the Maremane anticline and rests unconformably on dolomite and the BIF of the underlying strata Ghaap Plateau Formation. The succession consists of a basal conglomerate with pebbles of jasper and banded iron formation, shale and white to brown Iron and Manganese. The Makganyene Formation lies unconformably on the Gamagara Formation and has a maximum thickness of less than 480 m. Tillite occurs at the base of formation and contains fragments of black, white and red chert in a reddish-brown sandy ground mass. Higher up in the succession, alternating layers of grit, tillite, and silicified mudstone and feldspathic Iron and Manganese occur. Dolomite or limestone occur interbanded in mudstone (Moen et al., 1977).

The Ongeluk Formation forms the lower part of the Olifantshoek Group. The formation consists of greyish-green andesitic lava with amygdaloids and lenses of red jasper. The Voëlwater Formation overlies the Ongeluk Formation and has a thickness of 450 m. The lower beds are banded iron stone and banded red

jaspilite with chert, dolomite and lava. The upper portion of the succession consists predominantly of dolomite with chert, banded jasper and lava (Moen et al., 1977). The Lucknow Formation occurs east of the Olifantshoek Group in the Korannaberg where the strata are disturbed by a number of faults Figure 15. It lies unconformably on the Voëlwater Formation and is absent in places in the north. The formation has a maximum thickness of 1 500m. The lower portion consists mainly of shale with subordinate layers of Iron and Manganese and lava and an upper portion of whitish Iron and Manganese with lenses of flagstone and dolomitic limestone. The Hartley Formation, the upper part of Olifantshoek Group, follows conformably on the Lucknow Formation with a basal conglomerate containing pebbles of Iron and Manganese, jaspilite and lava. It is overlain by andesitic lava which contains amygdales, tuff, breccia and pebbles of Iron and Manganese (Moen et al., 1977). The Matsap Subgroup lie conformably on the Hartley Formation but in places is found unconformably on the Voëlwater Formation in the Korannaberg. Three members were recognized. They consist predominantly of sub-greywacke and purple, grey and brown Iron and Manganese with thin pebble beds and a layer of conglomerate in which quartz, banded iron formation and red jasper pebbles are abundant. The Brulsand Formation consists mainly of Iron and Manganese with subordinate shale and subgreywacke. Together with the Matsap Subgroup they form the Volop Group with a thickness of 500m (Moen et al., 1977).

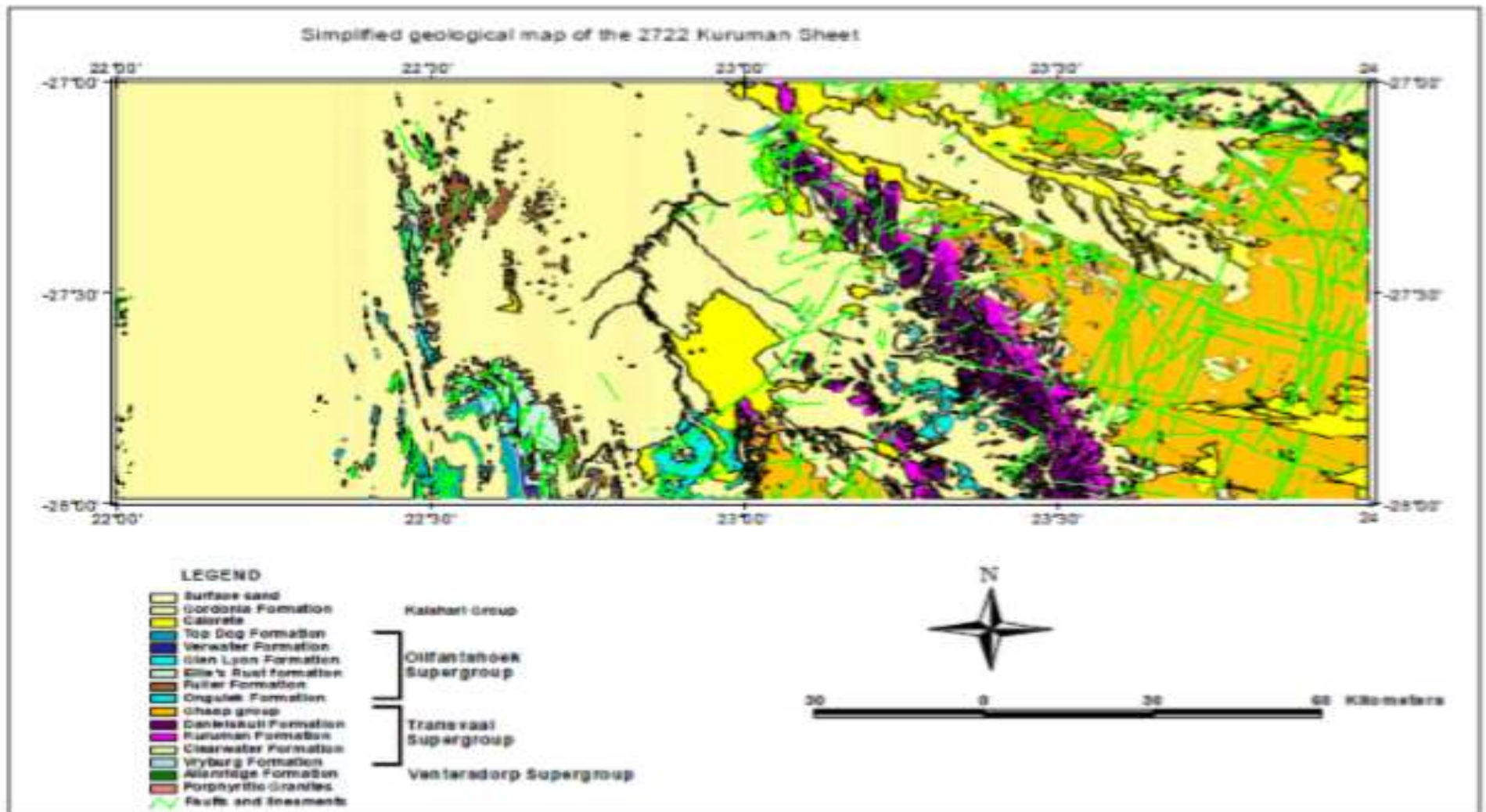

Figure 15: A simplified geological area of Kuruman (Moen, 1979)

Table 7: Lithostratigraphic column of the Kuruman Area

STRATIGRAPHY			DESCRIPTION	MAGNETIC EVENT
			Red to flesh-coloured wind-blown sand	
			Rubble	
			River-sand and gravel	
			Surface limestone	
OLIFANTSHOEK SUPERGROUP (±2 223-2 216 MA)	BRULPAN GROUP		Groblershoop Fm	Dolerite dykes
	VOLOP GROUP	Brulsand SBGRP	Top dog Fm	
			Verwater Fm	
		Matsap SBGRP	Glen Lyon Fm	
	Ellie's Rust Fm			
	Fuller Fm			
	Hartley Fm			
Lucknow Fm				
TRANVAAL SUPERGROUP (±2 224-2 219 MA)	KURU MAN GRO	Voëlwater SBGRP	Basic lava	
		Ongeluk Fm		
		Makganyene Fm		
	GHAAP GROUP	Campbell Rand SBGRP		Monteville Fm
		Asbestos Hills SBGRP		Danielskuil Fm
				Kuruman Fm
		Schmidtsdrif SBGRP		Clearwater Fm
Boomplaas Fm				
Vryburg Fm				
VENTERSDORP SUPERGROUP (±2 714 MA)		Allanrigde Fm	Andesitic lava, amygdaloid and agglomerate	Andesitic lava
Porphyritic granite (basement)				

9.1.3 Climate

The area of interest is situated approximately 46 km South of Kathu town. The climate is predominantly semi-arid with low rainfall and high evaporation. The mean annual precipitation of the application area is approximately 374 mm/a. Climate plays a vital role in determining the availability of water resources, the nature of the natural landscape and vegetation types. Temperatures are high during the summer and low during the winter. The coldest months are experienced from June to August while the hottest months range from September to March. The average daily temperatures range from 19°C in June, to 26.7°C in January. The mean maximum average temperature during the summer months is approximately 33°C, while during the winter months the mean average minimum temperature of approximately 3,1°C. The area also experiences extreme events on a regular basis, including frost, hail, drought, and high-speed winds. Prevailing winds are north-westerly and south easterly winds with an average speed of approximately 5 m/s, between the driest and wettest months; the difference in precipitation is 73 mm. During the year, the average temperatures vary by 15.3 °C.

Climate can influence the potential for environmental impacts and related mine design. Specific issues include:

- rainfall could influence erosion, evaporation, vegetation growth, rehabilitation planning, dust suppression, and surface water management planning;
- temperature could influence air dispersion through impacts on atmospheric stability and mixing layers, vegetation growth, and evaporation which could influence rehabilitation planning; and
- wind could influence erosion, the dispersion of potential atmospheric pollutants, and rehabilitation planning.

9.1.4 Agricultural Potential

Agricultural potential is expected to be low due to shallow sandy soils and climatic constraints. Specific limitations applicable to the area include shallow soils, unfavourable climate, low water-holding capacity, stony soils and rock outcrops and erosion hazards.

Currently, predominant land uses are mining and agriculture in the Gamagara area. However, generation of energy from renewable power source is becoming common in recent times. The single most influential factor to the development of the Gamagara area is Sishen Iron Ore mining development. The Gamagara area became known to the general South African community as a result of enormous number of jobs that are created by Sishen Iron Ore Mine. Not only does the mine provide jobs to thousands of job-seekers, it is also the single contributing factor to the planning and development of Kathu town.

9.1.5 Surface Water

There are neither perennial nor non-perennial rivers that traverse the area of application. The Gamagara River traverses South West of the area of application. The area of application is located within the Lower Vaal Water Management Area (WMA), in the D41J Quaternary Catchment drained by the endorheic Gamagara River. The regional drainage pattern of the area is primarily to the northwest in the direction of the endorheic Gamagara River, but most of the drainage lines in the mining area have historically been impacted on by mining activities. No wetlands, drainage patterns or rivers occur within the area of application.

9.1.6 Groundwater

Groundwater resource is valuable. Groundwater is defined as water that is located beneath the surface in soil, rock pore spaces and in the fractures of lithological formations. Groundwater resource is impacted by a number of activities such as domestic, agricultural and mining operations. Agriculture and mining may require dewatering services in order to operate effectively and efficiently whilst promoting environmental protection and for purposes of water supply.

The Gamagara area groundwater resource is limited. The local mining operations require significant quantities of groundwater to support operations. The nearest mining operations to the proposed Prospecting for Mineral Resources Project that also use groundwater to support their operations are Tshipi Borwa and Sishen Mines.

9.1.7 Topography

The area of application is characterised by a flat topography with gentle slope. The elevation ranges from approximately 1 233 m and 1 345 m. The terrain morphological class of the area can be described as plains with high relief, either isolated moderately or strongly undulating. The area lies at an altitude of 1 289 meters above sea level, with the highest elevations occurring in the South East corner. Sishen Airport is in the North West of the project area, so is the Kathu Solar Park in the West of the project area. The application area remains relatively undisturbed.

9.1.8 Biodiversity

The area of application lies within the Savanna biome that is characterised by grassy ground layer and woody plants. The Savanna biome is the largest biome in the Southern African region.

The application area is 9 000 hectares in size and it comprises of wooded tree, shrub species and protected tree species.

A comprehensive Biodiversity Assessment in relation to the proposed development is going to be conducted. Any area that has high population of protected plant species is going to be managed as per the provisions of applicable legislation.

9.1.9 Wetlands

A wetland as defined by the National Water Act refers to land which is transitional between terrestrial and aquatic systems where the water table is usually at or near the surface, or the land is periodically covered with shallow water and which under normal circumstances supports or would support vegetation typically adapted to life in water saturated soil. However, there are some wetlands (ephemeral pans) in the region surrounding the project area.

9.1.10 Waste

Waste is expected to be generated as a result of the proposed development and associated activities. It is proposed that waste that is generated on site should be separated at source. Waste Separation at Source pertains to setting aside post-consumer dry recyclable waste and household generated garden waste for the purpose of re-use, recycling, composting, or further processing of these materials.

Enormous value in waste separation at source emanates from, among others, procurement, recycling materials that are well sorted and uncontaminated. A basic requirement to achieve this value is that as much as possible, and efficiently as possible, waste or materials are separated early in the recycling process. This is separating waste at source essentially.

In South Africa, waste management is governed by the National Environmental Management: Waste Act, 2008 (Act No. 59 of 2008) which came into effect on 1 July 2009. Following the enactment of the NEM:WA, the Minister of Environmental Affairs established the National Waste Management Strategy (NWMS) to ensure the achievement the objectives of the NEM:WA. The NWMS was approved for implementation by the Cabinet in November 2011. The Waste Act supports the waste management hierarchy in its approach to waste management, by promoting cleaner production, waste minimisation, reuse, recycling and waste treatment with disposal seen as a last resort in the management of waste. There are a number of types of waste to be transported. Before any waste is transported, the person responsible for transporting such waste needs to assess the nature as well as the requirements for a specific load if waste to be transported.

Understandably the preparations for transporting building rubble for instance, would be different to that of medical waste.

9.1.11 Heritage and Cultural Resources

The existing heritage resources, if any, are going to be protected through demarcation of the NO-GO zone(s). All encountered graves, if any, are going to be preserved. Buffer zones may be built, at least 100 m away from the preserved heritage resource. Specialists and relevant authorities will be notified and called in should any Heritage Resources of significant importance be encountered. Alternatively, a procedure/protocol that is recommended by specialists may have to be followed.

A Heritage Impact Assessment (HIA) including a Palaeontological Impact Assessment (Desktop Study) is going to be conducted in respect of the proposed Prospecting for Mineral Resources Project.

9.1.12 Socio-economic

The proposed Prospecting for Mineral Resources Project is located near the Gamagara Local Municipality within the John Taolo Gaetsewe District Municipality which includes the towns of Kathu, Dibeng, Sesheng and Olifantshoek. Sishen Mine has played a significant role in the establishment and development of the town of Kathu and surrounds since 1953. The district is largely reliant on mining with mining contributing 55.5% to the district and 77.5% to the local municipal economy (Demacon, 2016). The mining sector is also the largest employer in the local economy. According to Demacon (2016) there are approximately 50 000 people living in the Gamagara municipal area of which 65% are economically active.

9.1.13 Land Uses

To achieve sustainable irrigation of soils, the appropriate soils need to be identified, to prevent water logging and salinization. During irrigation, considerable amounts of salts are applied with the water. When water is absorbed by plant roots through transpiration, the salts are precipitated in the soil and a long-term result is the increased concentration of salts called salinization. Salinization in the soil can hamper crop growth and in extreme cases salinization will render the soil non-vegetative. These effects can be negated with proper management on soils with specific properties. For this reason, the Department of Agriculture; Northern Cape, has provided guidelines to which soil properties must adhere before a ploughing license can be granted. A ploughing license is one of the requirements, which must be fulfilled before the Department of Water, and Sanitation will grant water rights for irrigation. An irrigation potential

soil survey will investigate the morphological, physical and chemical properties of soils related to drainage, salinization and sodicity, and indicate the areas where the soils are suitable for irrigation.

9.1.14 Visual Amenity

Activities and associated infrastructure possess potential to impact negatively on the visual aspect of the environment. Dust that is going to be generated from the proposed development he landscapes character, scenic quality among others.

There are approximately 23 Solar developments with either an approved Environmental Authorisation or applications under consideration within 30 Km radius of the proposed development. Additionally, the project area is within 8 Km of other civil aviation aerodrome.

Visual, scenic and cultural components of the environment can be seen as a resource, much like any other resource, which has a value to individuals, to society and to the economy of the region (Oberholzer, 2005). A Visual Impact Assessment (VIA) is a specialist study performed to identify the visual impacts of a proposed project on the surrounding environment. The proposed Project will be investigated in terms of the visual characteristics of the receiving environment.

The large size, strong regular geometry of solar facilities, and the use of mirrors or glass panels with metal supporting structures, may result in high visual contrast being created that is visible for long distances in many instances. In favourable viewing conditions, large facilities can be visible from a distance of 16km or greater; it should be noted however that viewed from such long distances, the facilities may not be recognisable as solar facilities. Built structures associated with solar power facilities would introduce complex, rectilinear geometric forms and lines and artificial looking textures and colours into the landscape; these would typically contrast markedly with natural appearing landscapes.

9.1.15 Noise and Vibration

There are activities that are conducted in the locality which cause noise pollution. Some of them cause some vibration of the ground. They include mining activities among others. All these aspects may cause a disturbance to receptors that are in the locality.

9.1.16 Traffic

The proposed development may increase traffic volumes in the locality. This is going to pose some risks to humans and animals. An increase in traffic volumes results in increase in air and noise pollution and possibility of accidents to occur.

9.1.17 Air Quality

The air quality of the pre-mining period is expected to have been of a better quality; however, the existing mines in the surrounding areas also contribute to the air quality degradation. The main concern in this regard would however be dust from the proposed diamond mining settling on surrounding areas. However, a dust control plan will be implemented for the proposed project in order to control any possible nuisance dust that might give rise from the surrounding. The main contaminants associated with the project includes: inhalable particulate matter less than 10 microns in size (PM₁₀), larger total suspended particulates (TSP) that relate to dust fallout, VOC, SO₂, NO₂ and gaseous emissions mainly from vehicles and generators. A change in ambient air quality can have health and/or nuisance impacts. Related mitigation measures focus on pollution prevention and monitoring.

9.1.18 Site Sensitivity

Site sensitivity of the area of application is crucial to establish. This is possible achieve after specialist studies have been conducted.

9.2 Site Selection Matrix

Due to the nature of the proposed development, the location of the facility is largely dependent on technical and environmental factors such as irrigation suitability, climatic conditions, solar irradiation and geology. The solar irradiation to which the Northern Cape Province is exposed indicates is indicative of potential for the solar power generation.

The receptiveness of the site to development includes the suitability of the area for the proposed Prospecting for Mineral Resources Project. The Farm Gamohaam No. 438, near Kuruman, John Taolo Gaetsewe District, Northern Cape, South Africa where the project is proposed to be located is considered favourable and suitable from a technical perspective due to the following characteristics:

- Climatic conditions: Climatic conditions are a factor to consider in determining whether or not the project will be viable from a socio-economic and environmental perspective as Prospecting for

Mineral Resources Project, powered using solar energy is directly dependent on the annual direct solar irradiation values of John Taolo Gaetsewe District;

- Topographic conditions and geology: The area of application for the proposed Prospecting for Mineral Resources Project. The topographical landscape of the area within which the proposed development is going to be built relatively of low slope ensuring safety and low risk of loose rocks rolling down;
- Land accessibility and availability: The piece of land of the Farm Gamohaam No. 438, near Kuruman, John Taolo Gaetsewe District, Northern Cape, South Africa is available for purposes of the proposed project. The road R31 passes through the application area; and
- Environmental sensitivity: Environmentally, the proposed project location is regarded as relatively limited ecological sensitivity in respect of receiving environment.

9.3 Concluding Statement on Alternatives

Based on the criteria set above, the Farm Gamohaam No. 438, near Kuruman, John Taolo Gaetsewe District, Northern Cape, South Africa is the preferred location thus far because an application was lodged with the DMRE in respect of the properties.

9. Potential Environmental Impacts

9.1 Construction Phase

These are impacts on the environment and socio-economic aspects that are expected to occur during the construction phase of the proposed Prospecting for Mineral Resources Project. It is intrinsic that such impacts are temporary in duration, but may have longer lasting effects e.g. pollution of a sensitive area during construction, could have effects that may last long after construction is over. Construction phase impacts could potentially include:

- Destruction or loss of biodiversity;
- Loss of medicinal flora;
- Proliferation of invasive and alien plant species;
- Reduction in Woody Alien Species;
- Visual Amenity;
- Faunal Mortality and Displacement (including CI species);
- Increase in dust and erosion degrading habitat integrity;

- Sensory disturbances;
- Destruction of Heritage and Cultural Resources;
- Social Impacts;
- Topography;
- Climate Change;
- Agricultural Impacts;
- Emissions from construction vehicles and generation of dust; and
- Pollution caused by spillage or discharge of construction waste water

Pollution of the groundwater and soil as a result of use of hydrocarbons and generation of infrastructural building rubble:

- Employment creation and skills development opportunities (Positive);
- Visual intrusion of construction/demolition activities;
- Noise impact from the use of construction and farming equipment;
- Health injuries to construction personnel as a result of construction work;
- Traffic, congestion and potential for collisions;
- Impacts on groundwater resources;
- Impact on agricultural potential and soils;
- Disturbance of flora and fauna;
- Increase in traffic volumes in the vicinity of the construction site;
- Windblown dust;
- Impact on heritage and cultural resources;
- Noise pollution; and
- Pollution of the environment with waste.

Based on the temporary duration of the construction phase and the fact that negative impacts of construction can be readily predicted and mitigated, generally speaking, more attention will be given to the operational phase impacts of the proposed Project than to the construction phase impacts. However, wherever relevant, specialist studies would consider construction phase impacts, and in certain cases, would be focused on construction phase impacts e.g. impacts on biodiversity are mainly construction phase-related impacts.

9.2 Operational Phase

The EIA phase is going to assess impacts associated with the operating the proposed project. Given the long-term effect of these impacts at operational phase, the EIA study is going to be comprehensive. The suggested specialist studies are expected to identify and assess the significance of these impacts and propose mitigation measures accordingly.

9.3 A Description of the Environmental Impacts and Risks Identified During the Environmental Assessment Process

This section describes potential impacts on environmental and socioeconomic pertaining to each of the fundamental project actions / activities, processes that will be followed and associated infrastructure that will be used in the proposed development (Please see Table 6).

Table 8: Environmental Impacts and Risks Identified

Activity/process or part thereof	Impacts (Pre-mitigation)
Vegetation Clearance, Ground Levelling and Sterilisation of Mineral Resources	Sterilisation of mineral resources Infrastructure, posing safety risks to personnel and animals Loss of soil and land capability affected through physical disturbance Physical destruction of biodiversity General disturbance of biodiversity Proliferation of Invasive and Alien Plant species Change in visual amenity Use of fertiliser Lowering of groundwater level Air pollution, greenhouse gas emissions, global warming Loss of heritage/cultural and palaeontological resources Influx of labour Wetlands Health and Safety Traffic Waste Agriculture Socio-economic impact Influx of labour Interference with existing land uses
Infrastructure, posing safety risks to personnel and animals	Sterilisation of mineral resources Infrastructure, posing safety risks to personnel and animals Loss of soil and land capability affected through physical disturbance Physical destruction of biodiversity General disturbance of biodiversity Proliferation of Invasive and Alien Plant species Change in visual amenity Use of fertiliser Lowering of groundwater level

	<p>Air pollution, greenhouse gas emissions, global warming Loss of heritage/cultural and palaeontological resources Influx of labour Wetlands Health and Safety Traffic Waste Socio-economic impact Influx of labour Interference with existing land uses</p>
<p>Water use and management; Waste Management</p>	<p>Sterilisation of mineral resources Infrastructure, posing safety risks to personnel and animals Loss of soil and land capability affected through physical disturbance Physical destruction of biodiversity General disturbance of biodiversity Proliferation of Invasive and Alien Plant species Change in visual amenity Use of fertiliser Lowering of groundwater level Air pollution, greenhouse gas emissions, global warming Loss of heritage/cultural and palaeontological resources Influx of labour Wetlands Health and Safety Traffic Waste Socio-economic impact Influx of labour Interference with existing land uses</p>
<p>Drilling, Pitting and Trenching, and associated activities (including services)</p>	<p>Sterilisation of mineral resources Infrastructure, posing safety risks to personnel and animals Loss of soil and land capability affected through physical disturbance Physical destruction of biodiversity General disturbance of biodiversity Proliferation of Invasive and Alien Plant species Change in visual amenity Use of fertiliser Lowering of groundwater level Air pollution, greenhouse gas emissions, global warming Loss of heritage/cultural and palaeontological resources Influx of labour Wetlands Health and Safety Traffic Waste Socio-economic impact Influx of labour Interference with existing land uses</p>

<p>Transport system</p>	<p>Sterilisation of mineral resources Infrastructure, posing safety risks to personnel and animals Loss of soil and land capability affected through physical disturbance Physical destruction of biodiversity General disturbance of biodiversity Proliferation of Invasive and Alien Plant species Change in visual amenity Use of fertiliser Lowering of groundwater level Air pollution, greenhouse gas emissions, global warming Loss of heritage/cultural and palaeontological resources Influx of labour Wetlands Health and Safety Traffic Waste Socio-economic impact Influx of labour Interference with existing land uses</p>
<p>Concurrent Backfilling (Rehabilitation)</p>	<p>Sterilisation of mineral resources Infrastructure, posing safety risks to personnel and animals Loss of soil and land capability affected through physical disturbance Physical destruction of biodiversity General disturbance of biodiversity Proliferation of Invasive and Alien Plant species Change in visual amenity Use of fertiliser Lowering of groundwater level Air pollution, greenhouse gas emissions, global warming Loss of heritage/cultural and palaeontological resources Influx of labour Wetlands Health and Safety Traffic Waste Socio-economic impact Influx of labour Interference with existing land uses</p>
<p>Use of facilities and services</p>	<p>Sterilisation of mineral resources Infrastructure, posing safety risks to personnel and animals Loss of soil and land capability affected through physical disturbance Physical destruction of biodiversity General disturbance of biodiversity Proliferation of Invasive and Alien Plant species Change in visual amenity Use of fertiliser Lowering of groundwater level</p>

	Air pollution, greenhouse gas emissions, global warming Loss of heritage/cultural and palaeontological resources Influx of labour Wetlands Health and Safety Traffic Waste Socio-economic impact Influx of labour Interference with existing land uses
Restoration of destructed biodiversity	Sterilisation of mineral resources Infrastructure, posing safety risks to personnel and animals Loss of soil and land capability affected through physical disturbance Physical destruction of biodiversity General disturbance of biodiversity Proliferation of Invasive and Alien Plant species Change in visual amenity Use of fertiliser Lowering of groundwater level Air pollution, greenhouse gas emissions, global warming Loss of heritage/cultural and palaeontological resources Influx of labour Wetlands Health and Safety Traffic Waste Socio-economic impact Influx of labour Interference with existing land uses
Closure , post-closure alternative land uses	Loss of job opportunities Economic impact Proliferation of Invasive and Alien Plant species

10. Conclusion and Recommendations

The Draft Scoping Report presented herein is open for public review at his stage. A revised and final copy of this report is going to be submitted to the Competent Authority for approval after comments have been received from the proponent, the public community, government departments and the Competent Authority.

11. Plan of Study for EIA

11.1 Introduction

This section gives a brief outline of the Plan of Study for EIA (PoSEIA) and the tasks that will be undertaken and the anticipated process to meet the objectives for the EIA phase. The approach to the EIA is to focus on those key issues identified for the preferred alternative. This will ensure that the EIA focuses on the most significant impacts and in the process save time and resources.

11.2 Process Phases

11.2.1 Scoping Phase

The Scoping Report presented herein is in respect of the proposed Project. Literature review, comments from Interested and Affected Parties and findings of specialists are going to inform the findings of the full Environmental Impact Assessment that is underway. There were no identified environmental fatal flaws in relation to the proposed development at the time of publishing this draft Scoping Report.

The EIA is going to be undertaken in order to present an assessment of these potential impacts and make recommendations on proposed mitigation measures. The EIA, as informed by literature review, comments received from interested and affected parties and findings and recommendations of specialists are also going to be used to collate all this information into a single coherent piece of work.

11.2.2 Environmental Impact Assessment

All potentially significant socio-economic and environmental impacts that are associated with the proposed development have been identified in the Scoping Study presented herein. However, these impacts are going to be revised before the submission of final Scoping Report copy to the Competent Authority. All the impacts are going to be investigated further during the EIA phase. The proposed mitigation measures are going to be presented accordingly.

11.3 Conduct Impact Assessment

11.3.1 Rating of Impact

The process for determining impact significance serves at least two purposes: first, it aids in highlighting the important impacts that must be taken into account during the management and approval process; second, it displays the primary impact characteristics that are used to determine impact significance.

When determining the significance of identified impacts, the following factors must be taken into account:

Severity

Indicates if an impact is harmful or not. A limited impact on the sterilization of any mineral resources would be shown by a study of the location of surface infrastructure and related operations. Prior to the effective implementation of suggested mitigation measures, severity will be assessed. The severity will be assessed after the planned mitigation measures have been implemented successfully.

Spatial Scope

The term "Extent of Influence" refers to the region that the impact will be felt. Bracketing ranges are frequently needed since an impact's severity and significance typically have separate scales. This is frequently helpful for further defining the determined significance or intensity of an impact during the project's detailed assessment phase. For instance, a value that is high locally but low regionally.

A relative word known as "spatial scale or extent" connects the determined impact to the geographical scale or extent of the projected development and the entire planet. Before planned mitigating measures are successfully executed, the extent is on-site. The extent is on-site following the successful deployment of the suggested mitigation measures.

Duration

specifies the impact's expected lifetime;

Because infrastructure will be used in most cases throughout construction and operation of the proposed development, the sterilisation of resources will be kept to a minimum. Following the successful execution of the suggested mitigation measures, the duration lasts the entire operational life.

Consequence

Prior to the effective implementation of suggested mitigating measures, the consequence is minimal. The impact is minimal following the successful implementation of the suggested mitigating measures.

Probability

describes the probability that an impact will actually occur; before suggested mitigation measures are effectively applied, the probability (synergy/summation) of impact frequency and activity frequency will be determined. Following the successful execution of the suggested mitigation strategies, such as, for example, choosing a site for the infrastructure and related operations in a way that will support preventative (avoid), minimization (reduce), control, and corrective actions (remedy).

Significance

Prior to the effective implementation of suggested mitigation measures, the significance will be calculated. The relevance will also be considered when the planned mitigation measures have been successfully implemented.

Cumulative Impact

When referring to an action, the term "impact" refers to the outcome of a particular undertaking that, while not necessarily significant in and of itself, may take on significance when combined with other comparable or unrelated activities taking place nearby.

In the context of a proposed development, the cumulative impact rating takes into account the anticipated effects, lingering effects, effects of other projects and activities in the form of potential synergistic, interactive system components, pattern, augmentative, consecutive impacts, and mitigation measures. Before specified mitigating measures are successfully executed, the overall impact is minimal.

The National Environmental Management Act of 1998 (Act No. 107 of 1998), as modified, and the Environmental Impact Assessment Regulations of 2017 are both in compliance with the technique of rating impact importance described here. Impact significance evaluation is a complex, step-by-step process. Several elements are taken into account when determining the impact importance rating. The actions that will be taken in this case involve identifying the Consequence (C) of each discovered potential impact while taking into account variables including the impact's nature, spatial scope, duration, severity, and reversibility. The probability of an impact occurring is the following stage. Environmental Risk of a specific impact is calculated as the sum of likelihood of occurrence and consequence. In addition, other elements including public concern, cumulative effects, and the possibility of irreparable resource loss are taken into account when determining Priority. Prioritization Factor (PF), which is derived from Priority, is used to calculate the Significance Rating (SR) of Impact. Authorities and stakeholders can use priority as a guide to help them decide on the development strategy in an educated manner. All identified alternatives will be subject to the impact assessment.

11.3.1.1 Impact Assessment, Rating and Mitigation

Below is a discussion of the criteria that were used to determine how significant the consequences were. The tables below display the parameters that were used to determine the importance of the impacts. The criteria for likelihood, intensity/severity, and relevance are based on experience and generalizations. We looked at both natural and already-existing mitigation strategies. The data offered in this piece of work

and the conclusions drawn therefrom are relative and not statistical; this also holds true for the terminology. Natural circumstances, circumstances incorporated into the project's design, and already-in-place management practices were all considered to be natural mitigating strategies. Mathematically, the following formula was used to determine the impacts' consequences:

$$C = \frac{\pm N \times (SS+D+S+R)}{4} \dots\dots\dots \text{Equation 1}$$

Where:

C = Consequence

R = Reversibility

N = Nature of impact

S = Severity

SS = Spatial Scope

D = Duration

Mathematically, Environmental Risk of impacts was calculated by using the following formula:

$$ER = C \times P \dots\dots\dots \text{Equation 2}$$

Where:

ER = Environmental Risk

P = Probability

C = Consequence

Further description of factors that are considered to determine Consequence using Equation 1 is presented in Table 7.

Table 9: Criteria for determination of ratings

Parameter	Points	Description
Nature	-1	Likely to result in a negative/ detrimental impact
	+1	Likely to result in a positive/ beneficial impact
Spatial Scope	1	Site (i.e. within the development property boundary)
	2	Local (i.e. within the local area or district)
	3	Provincial (i.e. within the entire province)
	4	National (i.e. within the country boundary)
Probability	1	Improbable (the possibility of the impact materialising is very low; <25%)
	2	Probable (there is a possibility that the impact will occur; >25% and <50%)
	3	High probability (the impact may occur; >50% and <100%)
	4	Definite (the impact will occur)
Duration	1	Immediate (<1 year)

	2	Short term (1-5 years)
	3	Medium term (6-15 years)
	4	Long term (the impact will cease after the operational life span of the project)
Severity	1	Low (affects the quality, use and integrity of the system/component in a way that is barely perceptible)
	2	Medium (where the affected environment is altered but natural, cultural and social functions and processes continue albeit in a modified way)
	3	High (where natural, cultural or social functions or processes are altered to the extent that it will temporarily cease)
	4	Very High (where natural, cultural or social functions or processes are altered to the extent that it will permanently cease)
Reversibility	1	Completely reversible (Impact is reversible without any effort, minimal mitigation, time and cost)
	2	Partly reversible (Impact is reversible without incurring significant time and cost with moderate effort and mitigation)
	3	Barely reversible (Impact is reversible only by incurring prohibitively high time and cost, involving intense mitigation)
	4	Irreversible (Impact is irreversible and no mitigation measures exist)
Parameter	Points	Description
Irreplaceable loss of resources	1	No loss of resource (Impact will not result in the loss of any resources)
	2	Marginal loss of resource (impact may result in the irreplaceable loss (cannot be replaced or substituted) of resources but the value (services and/or functions) of these resources is limited)
	3	Significant loss of resource (impact may result in the irreplaceable loss (cannot be replaced or substituted) of resources of high value (services and/or functions))
	4	Complete loss of resource (Impact is going to result in a complete loss of all resources)
Cumulative impact	1	Low cumulative impact (Considering the potential incremental, interactive, sequential, and synergistic cumulative impacts, impact would result in no to negligible cumulative change)
	2	Moderate cumulative impact (Considering the potential incremental, interactive, sequential, and synergistic cumulative impacts, it is less likely that the impact will result in visual, spatial and temporal cumulative change)
	3	Medium cumulative impact (Considering the potential incremental, interactive, sequential, and synergistic cumulative impacts, it is probable that the impact will result in visual, spatial and temporal cumulative change)
	4	High cumulative impact (Considering the potential incremental, interactive, sequential, and synergistic cumulative impacts, it is highly probable/ definite that the impact will result in spatial and temporal cumulative change)
Public Response	1	Low public response as the issue is not raised.
	2	Medium public response as the issue was raised meaningfully and justifiably.
	3	High public response as the issue was emphasised repeatedly
Formula used to determine Environmental Risk: (Consequence x Probability)		
Parameter	Points	Description

Environmental Risk	1 – 4	Positive low impact
	1 – 4	Negative low impact
	5 – 8	Positive medium impact
	5 – 8	Negative medium impact
	9 – 12	Positive high impact
	9 – 12	Negative high impact
	13 – 16	Positive very high impact
	13 – 16	Negative very high impact

Results for determination of Environmental Risk using Equation 2 are presented differently in Table 8.

Table 10: Determination of Environmental Risk

Environmental Risk										
-16	-12	-8	-4	-4	Consequence	4	4	8	12	16
-12	-9	-6	-3	-3		3	3	6	9	12
-8	-6	-4	-2	-2		2	2	4	6	8
-4	-3	-2	-1	-1		1	1	2	3	4
4	3	2	1			1	2	3	4	
Probability										

IMPACT PRIORITISATION

Further to the assessment criteria presented in the section above, it is necessary to assess each potentially significant impact in terms of:

- Public Response;
- Cumulative impacts; and
- The degree to which the identified impact may cause irreplaceable loss of resources.

The triple bottom line (environment, social, and economic aspects) should be taken into account when making decisions, and this includes the public's reaction to a proposed development and any potential resultant effects as

well as changes to the environment brought on by past, present, and future human activities as well as natural processes. It is suggested that in an effort to quantify even more factors during impact assessment, a factor like the Prioritization Factor be taken into account.

Mathematically, Prioritisation may be determined as presented in Equation 3.

$$Priority = PR + CI + LR \dots\dots\dots Equation 3$$

The priority ratings range from 3 to 11 and are presented in Table 9 and Significance Rating of Impacts in presented in Table 10.

Table 11: Determination of Prioritisation Factor

Priority	Rating	Prioritisation Factor
3	Low	1.00
4	Low	1.17
5	Medium	1.33
6	Medium	1.50
7	Medium	1.67
8	High	1.83
9	High	2.00
10	Very High	2.17
11	Very High	2.33

If all of the priority qualities are high, we raise priority by a factor of 0.5 in an effort to boost the post-mitigation environmental risk assessment (i.e. if environmental risk is high after the conventional impact rating, but there is high Public Response for example, then the net result would be to possibly upscale the impact to a very high significance rating). The product of Prioritisation Factor and Environmental Rating is results in relative quantity of Significance Rating of identified impact (Please see Equation 4).

$$SR = PF \times ER \dots\dots\dots Equation 4$$

Table 12: Significance Rating

Significance Rating	
Limits	Description
≤-30	Very High Negative (impacts that can be classified as fatal flaws and which are of such significance that it cannot be successfully mitigated).

>-30 & ≤-20	High Negative (impacts must influence a decision in respect of whether or not the proposed development may go ahead).
>-20 & ≤-10	Medium Negative (impacts could influence a decision in respect of the proposed project).
>-10 & <0	Low Negative (impacts have minimal influence on a decision in respect of the proposed project).
0	No impact
> 0 & < 10	Low Positive (impacts have minimal influence on a decision in respect of the proposed project).
≥ 10 & < 20	Medium Positive (impacts could influence a decision in respect of the proposed project).
≥ 20 & < 30	High Positive (impacts must influence a decision in respect of whether or not the proposed development may go ahead).
≥ 30	Very High Positive (impacts that can be classified as inventive best practices and which are of such significance that it contributes new knowledge).

The impact assessment criteria presented herein is going to be considered in conducting the study underway.

11.4 Anticipated Outcomes of the Impact Assessment Phase

The purpose of the EIA phase is going to assess issues identified in the scoping phase and will include an environmental management programme (EMPr). The EMPr will provide information on the proposed activity and the manner in which potential impacts will be minimized or mitigated. The EIA report will comply with *Appendix 3* of EIR Regulation of 2017 and will:

- Determine the policy and legislative context within which the activity is located and document how the proposed activity complies with and responds to the policy and legislative context;
- Describe the need and desirability of the proposed activity, including the need and desirability of the activity in the context of the preferred location;
- Identify the location of the development footprint within the preferred site based on an impact and risk assessment process inclusive of cumulative impacts and a ranking process of all the identified development footprint alternatives focusing on the geographical, physical, biological, social, economic, heritage and cultural aspects of the environment;
- Determine the—
 - (i) nature, significance, consequence, extent, duration and probability of the impacts occurring to inform identified preferred alternatives; and
 - (ii) degree to which these impacts-
 - (aa) can be reversed;

(bb) may cause irreplaceable loss of resources, and
(cc) can be avoided, managed or mitigated;

- Identify the most ideal location for the activity within the preferred site based on the lowest level of environmental sensitivity identified during the assessment;
- Identify, assess, and rank the impacts the activity will impose on the preferred location through the life of the activity;
- Identify suitable measures to avoid, manage or mitigate identified impacts; and
- Identify residual risks that need to be managed and monitored.

11.5 Proposed Specialist Studies

11.5.1 Heritage Impact Assessment (Field Survey), inclusive of Palaeontological Impact Assessment (Desktop Study)

A Palaeontological Impact Assessment (Desktop) will be conducted for the proposed Prospecting for Mineral Resources Project, which is located near Kuruman, Hay District, Northern Cape Province. In order to comply with the South African Heritage Resources Agency (SAHRA) in terms of Section 38(8) of the National Heritage Resources Act, 1999 (Act No. 25 of 1999) (NHRA), a desktop Palaeontological Impact Assessment (PIA) will be completed for the proposed project. The palaeontological sensitivity of the area under consideration will be presented. As part of the palaeontological context, information on fossils, among others, will be presented.

A Heritage Impact Assessment (Field Survey) will be undertaken in terms of Section 38 of the National Heritage Resources Act (Act No. 25 of 1999). The heritage sensitivity of the property will be assessed in terms of Stone Age, the Iron Age, Historical structures and Burial grounds among others.

11.5.2 Biodiversity Assessment Study

The Biodiversity Assessment study is required in order to identify sensitive biodiversity areas and protected fauna and flora on the site. A comprehensive investigation will be undertaken to identify potential floral species of special concern, this includes all IUCN listed species, TOPS listed species and species listed in schedule 1 and 2 of the NCNCA among others. The study may propose protection of certain sensitive areas such as wetlands and pans (among other) on site. The report and survey must comply with the NEMA Appendix 6 requirements.

11.5.3 Air Quality Impact Assessment

In recent times, it has become prevalent to undertake the Baseline Air Quality, Greenhouse Gas Emissions and Climate Change Impact Assessment for various Proposed Prospecting Activities Project: Air Quality, Greenhouse Gas Emissions and Climate Change Impact Assessment.

The proposed study is going to deal primarily with the assessment of air quality, GHG emissions and climate change impacts that are associated with prospecting or mining of an opencast operation and other related applicable infrastructure, tools, equipment and services to be developed, utilised and rendered as part of the proposed prospecting Project.

The report was compiled to address four thematic areas with the purpose of contributing to the Integrated Environmental Authorisation (IEA) application process as stated below:

- **Greenhouse Gas Emissions and Climate Change Impact Assessment;**
- **Baseline Air Quality Impact Assessment (AQIA);**
- **Health Risk Screening;**
- **Associated Management Plans.**

This report includes the following explanatory baseline study:

- a summary of the policy and legislative context within which air quality, GHG emissions and climate change;
- processing of data and information pertinent to Farm Gamohaam No. 438 Prospecting Right and neighbouring areas;
- identification of the Airshed and potential receptors in the vicinity of the proposed development;
- description of baseline air quality conditions around the application area and the kind of impact the proposed development could have on the identified sensitive receptors;
- discussion of greenhouse gas emissions associated with the applicable phase of the proposed development;
- proposal of a platform to raise applicable air quality concerns in relation to the proposed development;
- contextualizing the bases for undertaking the air quality, GHG emissions and climate change impact assessment determining the significance of identified impacts;
- qualitative assessment of potential impacts, including health risk screening in the context of air quality around the area of application and surrounding environment in respect of the proposed Farm Gamohaam No. 438 Prospecting Project;

- compilation of a comprehensive emissions inventory with due regard for the operational phase in respect of the prospecting activities;
- air dispersion modelling in order to estimate pollutant concentrations at ambient environmental conditions, in relation to the applicable NAAQS and pre-defined thresholds, that would be emitted from the prospecting activities on the identified receptors;
- proposal of associated management and monitoring plans as well as mitigation measures, based on the findings of this study, to promote sustainable development;
- recommendation of a monitoring system and Chance Find Protocol;
- literature review in relation to air quality, GHG emissions, climate change impact assessment; and
- sourcing information pertaining to historical mining, if any, around the study area.

The Technical Guidelines for Monitoring, Reporting, and Verification of GHG Emissions by Industry, which were created by the DEA in April 2017, were followed in compiling the greenhouse gas emissions inventory for the planned Farm Gamohaan No. 438 Prospecting Project.

11.5.4 Wetland Assessment

The issues raised in the Environmental Impact Assessment, which cannot be effectively addressed with the currently available information, form the basis for the terms of reference of specialist studies (DEAT, 2002).

The Wetland Assessment provides a baseline description of the proposed project area, specifically focussing on the Matlhwaring River System and the cluster of pans within and in the vicinity of the application area. The potential impacts of the proposed prospecting project on the Wetlands and / or pans' environment will be identified and assessed in terms of an assessment methodology that is presented in this report. Mitigation measures are proposed to enhance the positive impacts and reduce the significance of the negative impacts.

This wetland assessment is designed to define wetland areas within the proposed Prospecting Right area and to identify the ecological relevance of each assessed wetland area. This survey supports the following regulations and regulatory procedures:

- Section 19 of the National Water Act, 1998 (Act No. 36, 1998);
- Section 21 (c), (e), (g) and (i) of the National Water Act, 1998 (Act No. 36 of 1998);

- Section 21 of the Environment Conservation Act, 1989 (Act No. 73 of 1989);
- Section 24 of the Constitution of the Republic of South Africa, 1996;
- Section 5 of the National Environmental Management Act, 1998 (Act No. 107 of 1998);
- Delineate wetlands that are identified within 500m from the prospecting right application area at desktop level;
- Determine the functionality of wetlands within 500m from prospecting right application area, using a Level 1 Wet-EcoServices (Kotze *et al.*, 2005) assessment;
- Determine the Present Ecological Status (PES) of wetlands within 500m from the prospecting right application area through applying a Level 1 Wet-Health assessment (Macfarlane *et al.*, 2008);
- Determine the Ecological Importance and Sensitivity (EIS) of identified wetlands within 500m from the prospecting right application area; and
- Complete DWS Risk assessment matrix in order to gauge potential risks in relation to wetlands or river that is located within 500 m from the prospecting right application area.

11.5.5 Social Impact Assessment

It is proposed that a Social Impact Assessment is undertaken as part of the specialist studies for the proposed Project. The SIA will identify and assess the negative and positive social impacts (including cumulative impacts and social risks) associated with the proposed Project and develop feasible measures to avoid, mitigate and / or enhance these impacts. The findings of the SIA will be incorporated into the Environmental Impact Assessment / Basic Assessment Report and Environmental Management Programme for the proposed Project.

National Environmental Management Act, 1998 (Act No. 107 of 1998) (NEMA) as amended requires the identification, prediction and evaluation of the impact of specified projects on the environment, socio-economic conditions and cultural heritage of a local area through all project cycles (including construction, operations and closure) with a view to minimising negative impacts and maximise project benefits. The 'polluter pays principle' also applies namely that the costs of remedying pollution, environmental degradation and consequent health effects must be paid for by culprits.

In the 2002 Johannesburg Declaration on Sustainable Development, the on-going threats facing our planet were detailed, which include among others, loss of biodiversity, desertification of fertile land and water pollution. The alarming statistics on increasing environmental degradation is a result of numerous

contributing factors such as disharmony in the relationship between humanity and the earth, the cumulative impact of many minor human acts, and the emphasis on specialisation, thereby ignoring other contributing factors to the total challenge or problem. In the National Environmental Management Act, 1998 (Act No. 107 of 1998), the concept of “sustainable development” is defined in section 1 to mean- “...the integration of social, economic and environmental factors into planning, implementation and decision-making so as to ensure that development serves present and future generations”.

11.6 Compile the Environmental Impact Assessment Report

The EIA Report will include and address the following:

- A project description (including a description of the proposed activity, plans illustrating the study area and proposed site, and detailed technical details regarding the proposed project);
- A description of the pre-construction environment;
- A description of the public participation process, including the identification of I&APs, a record of the procedures followed, and the perceptions and views of the I&APs regarding the activity;
- A description of socio-economic and environmental issues identified and potential impacts of the proposed project on these aspects (i.e., how the environment may be affected as a result of the proposed activity)
- Assessment of impacts identified in the Scoping Study which were determined to be significant. These impacts will be assessed in terms of the nature, extent, duration, intensity, severity and probability of the impact occurring; and
- Conclusions and recommendations regarding the presence of any environmental fatal flaws and recommendations (including a preferred site and mitigation and management measures) regarding the proposed project.

Furthermore, the EIA Report will comply with Regulation 23 – *Appendix 3* of the EIA Regulations 2017 and other applicable regulations/guidelines insofar as content and issues addressed are concerned. The integration of the specialist studies into a consolidated report will allow for easy assessment of the potential environmental aspects. In order to evaluate the significance of the identified impacts, the following characteristics of each potential impact will be identified.

11.7 Review of Environmental Impact Assessment Report

11.7.1 Public Review of the Draft Environmental Impact Assessment Report

The draft Environmental Impact Assessment Report will be made available at public places for public review and comment, in accordance with the EIA Regulations. A 30-day period will be allowed for this review process. An advert indicating the availability of this report and the information regarding the public meeting will be placed in the local newspaper. In addition, all I&APs registered on the project database will be notified of the public meeting and the availability of this report by letter.

11.7.2 Authority Review of the Draft Environmental Impact Assessment Report

The Environmental Impact Report will be submitted to DMRE for review and comment. The draft report will not be made available to the authorities as they are not obligated to review Draft reports in terms of the Regulations. All I&AP comments received during the 30-day public review period will be incorporated into a final Environmental Scoping Report. This final report will be submitted to the Authorities for their review and consideration.

12. An undertaking or affirmation by the EAP in relation to [-]

The undertaking required to meet the requirements of this section is provided at the end of the Scoping Report.

The correctness of the information provided in the reports

I, Kwindla Nobaza, hereby undertake that the information provided in the foregoing report is correct to the best of my knowledge and that the comments and inputs from stakeholder and Interested and Affected Parties have been correctly recorded in the report.

Signature of the EAP

Date: 07 July 2023

The inclusion of comments and inputs from stakeholders and I&APs

I, Kwindla Nobaza, hereby undertake that the information provided in the foregoing report is correct to the best of my knowledge and the level of agreement with stakeholder and Interested and Affected Parties have been correctly recorded and reported herein.

Signature of the EAP

Date: 07 July 2023

The inclusion of inputs and recommendations from the specialist reports where relevant; and

I, Kwindla Nobaza, hereby undertake that the information provided in the foregoing report is correct to the best of my knowledge and that the comments and inputs from stakeholder and Interested and Affected Parties have been correctly recorded in the report.

Signature of the EAP

Date: 07 July 2023.

ANNEXURE A
COPY OF CERTIFICATE _ ENVIRONMENTAL ASSESSMENT PRACTITIONER

**ANNEXURE B
ENLARGED MAPS**

**ANNEXURE C
PUBLIC PARTITIPATION RECORDS**